

ENGINEERING  
TOMORROW

*Danfoss*

Technical Information

# H1 Axial Piston Single Pumps

## Size 115/130



**Revision history***Table of revisions*

<b>Date</b>	<b>Changed</b>	<b>Rev</b>
May 2018	Angle sensor for EDC, FDC note added.	0901
May 2017	NFPE gen. 3 changes.	0801
March 2016	Minor edit	0701
November 2015	Master Model Code changes.	0700
2010-2014	Various changes.	BA-GB
Jul 2009	First edition	AA

## Contents

### Technical specifications

H1 Pumps General Specification.....	6
H1P 115/130 Technical Data.....	6
H1P 115/130 Operating Parameters .....	8
Fluid Specifications .....	9
Bearing Life and External Radial Shaft Loads.....	9
H1P 115/130 Mounting Flange Loads .....	10
Charge pump.....	11
Charge Pump Selection.....	11
26/34 cm <sup>3</sup> Charge Pump – Flow and Power Curves.....	11

### Master Model Code

### Control Options

Electrical Displacement Control (EDC).....	19
EDC Control Signal Requirements.....	19
EDC Solenoid Data.....	20
Control Response.....	20
Response Time, EDC 115/130.....	21
Manual Displacement Control (MDC) .....	22
MDC Torque.....	22
MDC General Information.....	23
MDC Shaft Rotation.....	23
Control Response.....	24
MDC Response Time.....	24
Neutral Start Switch (NSS).....	24
Connector.....	25
Case Gauge Port M14.....	25
Lever.....	25
Forward-Neutral-Reverse Electric Control (FNR).....	26
Control Response.....	28
Response Time, FNR 115/130.....	28
Non Feedback Proportional Electric Control (NFPE).....	29
Control Signal Requirements, NFPE 115/130.....	29
Control Response.....	31
NFPE Response Time.....	31
Automotive Control (AC).....	32
Mode types.....	32
Basic functions.....	32
Performance functions.....	33
Protection and safety functions.....	33
Engine control and protection.....	33
Installation features.....	33
Fan Drive Control (FDC).....	34
Control Signal Requirements, FDC 115/130.....	34
Control Response.....	36
Response Time, FDC 115/130.....	36
Manual Over Ride (MOR).....	37
Swash Plate Angle Sensor for EDC Controls.....	38
Swash Plate Angle Sensor Parameters (EDC).....	38
Swash Plate Angle Sensor Connector.....	39
Interface with ECU.....	39
Swash plate angle sensor for NFPE and AC2 controls.....	40
Swash Plate Angle Sensor Parameters (NFPE/AC).....	40
Swash Plate Angle Sensor Connector.....	41
Interface with ECU.....	41
Control-Cut-Off valve (CCO valve).....	42
CCO solenoid data.....	43
Brake gauge port with MDC.....	43
Displacement limiter.....	43

**Contents**

H1P 115/130 Displacement Change (Approximately).....	43
--	----

**Dimensions**

H1P input shaft - Option G3 (SAE D, 13 teeth).....	44
H1P input shaft - Option G2 (SAE D, 27 teeth).....	45
H1P input shaft - Option F3, Code 44-3.....	46
Tapered shaft customer acknowledgement.....	47
H1P 115/130 Auxiliary mounting - Option H1 (SAE A, 11 teeth).....	48
H1P 115/130 Auxiliary mounting - Option H2 (SAE A, 9 teeth).....	49
H1P 115/130 Auxiliary mounting - Option H3 (SAE B, 13 teeth).....	50
H1P 115/130 Auxiliary mounting - Option H4 (SAE D, 13 teeth).....	51
H1P 115/130 Auxiliary mounting - Option H5 (SAE B-B, 15 teeth).....	52
H1P 115/130 Auxiliary mounting - Option H6 (SAE C, 14 teeth).....	53
H1P 115/130 Auxiliary mounting - Option S1 (SAE B-B, 14 teeth).....	54
H1P 115/130 displacement limiter, option B and D.....	55

**Installation drawings**

Port Description H1P115/130.....	56
Dimensions H1P 115/130.....	58

**Controls**

Electric Displacement Control (EDC), option A2 (12 V) / A3 (24 V) .....	61
Electric Displacement Control (EDC) with MOR, options A4 (12 V) / A5 (24 V).....	61
H1P 115/130 Manual Displacement Control (MDC), option M1.....	62
H1P 115/130 Manual Displacement Control (MDC) with NSS, option M2.....	63
H1P 115/130 Manual Displacement Control (MDC) with CCO, option M3, M4.....	64
H1P 115/130 Manual Displacement Control (MDC) with NSS and CCO, option M5, M6.....	65
Non Feedback Proportional Electric control (NFPE), with manual override, option A8 (12 V) / B8 (24 V)....	66
Automotive Control (AC) Dimensions.....	67
Forward-Neutral-Reverse (FNR) with manual override, options A9 (12 V) / B1 (24 V).....	68

**Filtration**

H1P 115/130 suction filtration, option L.....	69
H1P 115/130 filtration, option M.....	70

## **Technical specifications**

**Technical specifications**
**H1 Pumps General Specification**

Axial piston closed circuit variable displacement pump of cradle swash-plate design with clockwise or counterclockwise direction of rotation.

**Pipe connections**

- Main pressure ports: ISO split flange boss
- Remaining ports: SAE straight thread O-ring boss

**Recommended installation position**

Pump installation position is discretionary, however the recommended control position is on the top or at the side with the top position preferred. If the pump is installed with the control at the bottom, flushing flow must be provided through port M14 located on the EDC, FNR and NFPE control.

Vertical input shaft installation is acceptable. If input shaft is at the top, 1 bar case pressure must be maintained during operation.

The housing must always be filled with hydraulic fluid.

Recommended mounting for a multiple pump stack is to arrange the highest power flow towards the input source.

Consult Danfoss for nonconformance to these guidelines.

**Auxiliary cavity pressure**

Auxiliary cavity pressure will be inlet pressure with internal charge pump or case pressure with external charge supply. For reference see [H1P 115/130 Operating Parameters](#) on page 8. Please verify mating pump shaft seal capability.

**H1P 115/130 Technical Data**

Feature	Size 115	Size 130
<b>Displacement</b>	115.2 cm <sup>3</sup> [7.03 in <sup>3</sup> ]	130.0 cm <sup>3</sup> [7.93 in <sup>3</sup> ]
<b>Flow at rated speed (continuous)</b>	371 l/min [98 US gal/min]	419 l/min [111 US gal/min]
<b>Torque at maximum displacement (theoretical)</b>	1.83 N·m/bar [1120 lbf·in/1000 psi]	2.07 N·m/bar [1260 lbf·in/1000 psi]
<b>Mass moment of inertia of rotating components</b>	0.021 kg·m <sup>2</sup> [0.0155 slug·ft <sup>2</sup> ]	0.0094kg·m <sup>2</sup> [0.0069 slug·ft <sup>2</sup> ]
<b>Mass (dry – no charge pump or auxiliary mounting flange)</b>	83 kg [187 lb]	83 kg [187 lb]
<b>Oil volume</b>	2.0 l [0.5 US gal]	2.0 l [0.5 US gal]

*Shaft, flange and ports description*

<b>Input shaft outer diameter, ISO 3019-1 splined or tapered shaft</b>	<ul style="list-style-type: none"> <li>• Outer Ø44 mm – 4 (SAE D, 13 teeth)</li> <li>• Outer Ø44 mm – 4 (SAE D, 27 teeth)</li> <li>• Conical keyed shaft end similar to ISO 3019-1 code 44-3, taper 1:8</li> </ul>
<b>Mounting flange per ISO 3019-1</b>	Flange 152-4 (SAE D)

## Technical specifications

*Shaft, flange and ports description (continued)*

<b>Auxiliary mounting flange with metric fasteners, with shaft outer diameter and splines per ISO 3019-1</b>	<ul style="list-style-type: none"> <li>• Flange 82-2 Outer Ø16 mm – 4 (SAE A, 9 teeth)</li> <li>• Flange 82-2 Outer Ø19 mm – 4 (SAE A, 11 teeth)</li> <li>• Flange 101-2 Outer Ø22 mm – 4 (SAE B, 13 teeth)</li> <li>• Flange 101-2 Outer Ø25 mm – 4 (SAE B-B, 15 teeth)</li> <li>• Flange 127-4 Outer Ø32 mm – 4 (SAE C, 14 teeth)</li> <li>• Flange 152-4 Outer Ø44 mm – 4 (SAE D, 13 teeth)</li> </ul>
<b>Suction port</b>	ISO 11926-1 – 1 <sup>5</sup> / <sub>8</sub> -12 (SAE O-ring boss)
<b>Main configuration port</b>	Ø31.5 - 450 bar split flange boss per ISO 6162, M12x1.75
<b>Case drain ports L2, L4</b>	ISO 11926-1 – 1 <sup>5</sup> / <sub>16</sub> -12 (SAE O-ring boss)
<b>Other ports</b>	SAE O-ring boss
<b>Customer interface threads</b>	Metric fasteners

**Technical specifications**

**H1P 115/130 Operating Parameters**

Feature		Size 115/130
<b>Input speed</b>	<b>Min. for internal<sup>1)</sup> and external<sup>2)</sup> charge supply.</b>	500 min <sup>-1</sup> (rpm)
	<b>Min. for full performance internal charge supply</b>	1200 min <sup>-1</sup> (rpm)
	<b>Rated</b>	3200 min <sup>-1</sup> (rpm)
	<b>Maximum</b>	3400 min <sup>-1</sup> (rpm)
<b>System pressure</b>	<b>Max. working</b>	450 bar [ 6528 psi]
	<b>Maximum</b>	480 bar [ 6960 psi]
	<b>Max. low loop</b>	45 bar [ 650 psi]
	<b>Min. low loop</b>	10 bar [ 145 psi]
<b>Charge pressure</b>	<b>Minimum</b>	16 bar [ 232 psi]
	<b>Maximum</b>	34 bar [ 493 psi]
<b>Control pressure</b>	<b>Min. at corner power for EDC and MDC</b>	17 bar [ 247 psi]
	<b>Min. at corner power for NFPE</b>	25 bar [ 363 psi]
	<b>Maximum</b>	34 bar [ 493 psi]
<b>Charge pump inlet pressure</b>	<b>Rated</b>	0.7 bar (absolute) [ 9.0 in Hg vacuum]
	<b>Min. (cold start)</b>	0.2 bar (absolute) [ 24.0 in Hg vacuum]
	<b>Maximum</b>	4.0 bar [ 58.0 psi]
<b>Case pressure</b>	<b>Rated</b>	3.0 bar [ 44.0 psi]
	<b>Maximum</b>	5.0 bar [ 73.0 psi]
<b>Lip seal pressure</b>	Max. (external)	0.4 bar [ 5.8 psi]

<sup>1)</sup> Performance (displacement and pressure) may be limited due to limited control pressure.

<sup>2)</sup> Full performance (displacement and pressure) possible at (at minimum charge pressure and control pressure supply).

## Technical specifications

### Fluid Specifications

#### Viscosity

Intermittent <sup>1)</sup>	Minimum	Recommended range	Maximum
5 mm <sup>2</sup> /s [42 SUS]	7 mm <sup>2</sup> /s [49 SUS]	12 – 80 mm <sup>2</sup> /s [66 – 370 SUS]	1600 mm <sup>2</sup> /s [7500 SUS]

<sup>1)</sup> Intermittent = Short term  $t < 1$  min per incident and not exceeding 2 % of duty cycle based load-life

#### Temperature

Minimum (cold start)	Rated	Recommended range*	Maximum Intermittent <sup>1)</sup>
-40°C [-40°F]	104°C [220°F]	60 – 85°C [140 – 185°F]	115°C [240°F]

\* At the hottest point, normally case drain port

<sup>1)</sup> Intermittent = Short term  $t < 1$  min per incident and not exceeding 2 % of duty cycle based load-life

#### Filtration, Cleanliness level and Efficiency $\beta_x$ -ratio ( Recommended Minimum)

<b>Cleanliness per ISO 4406</b>	22/18/13
<b>Efficiency <math>\beta_x</math> (charge pressure filtration)</b>	$\beta_{15-20} = 75$ ( $\beta_{10} \geq 10$ )
<b>Efficiency <math>\beta_x</math> (suction and return line filtration)</b>	$\beta_{35-45} = 75$ ( $\beta_{10} \geq 2$ )
<b>Recommended inlet screen mesh size</b>	100 – 125 $\mu\text{m}$

### Bearing Life and External Radial Shaft Loads

All external shaft loads affect bearing life. The pumps are designed with bearings that can accept some external radial loads. The external radial shaft load limits are a function of the load position and orientation, and the operating conditions of the unit.

Danfoss recommends clamp-type couplings for applications with radial shaft loads. Contact your Danfoss representative for an evaluation of unit bearing life if you have continuously applied external loads exceeding 25 % of the maximum allowable radial load ( $R_e$ ) or the pump swash-plate is positioned on one side of center all or most of the time.

#### Maximum external shaft load based on shaft deflection

External radial moment	Unit	Size 115	Size 130
$M_e$	N·m [lbf·in]	129 [1140]	129 [1140]

External radial shaft loads impact lifetime. For lifetime calculations please contact your Danfoss representative. In applications with external shaft loads, minimize the impact by positioning the load at 0° or 180° as shown below.

#### Radial load position

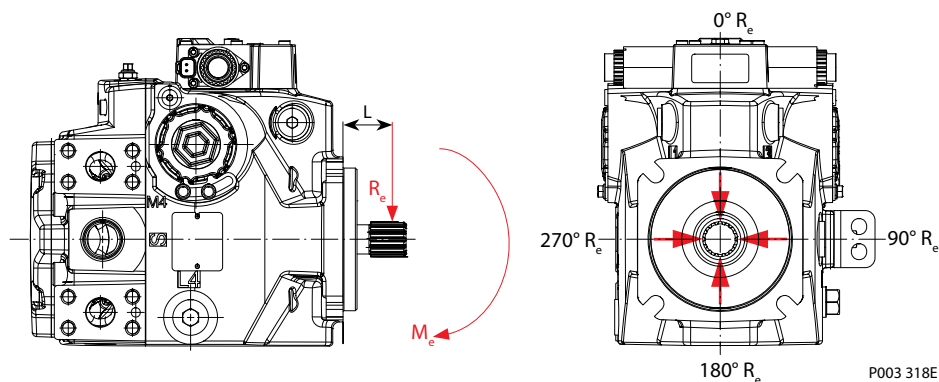

P003 318E

**Technical specifications**

The maximum allowable radial shaft load ( $R_e$ ) is based on the maximum external moment ( $M_e$ ) and the distance ( $L$ ) from the mounting flange to the load. It may be determined using the following formula:

$$R_e = \frac{M_e}{L}$$

---

Thrust loads should be avoided. Contact your Danfoss representative in the event thrust loads are anticipated.

---

**H1P 115/130 Mounting Flange Loads**

The Rated and Shock load moments apply for top or side orientation of control.

*Mounting flange load with control on top*

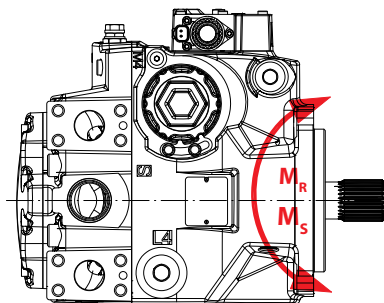

P001 916

**Rated moment**

$M_R = 5933 \text{ N}\cdot\text{m} [52\ 510 \text{ lbf}\cdot\text{in}]$

**Shock load moment**

$M_S = 12\ 640 \text{ N}\cdot\text{m} [111\ 870 \text{ lbf}\cdot\text{in}]$

---

For more information, see *H1 Axial Piston Pumps, Basic Information*, **BC0000057**, the section "Mounting flange loads".

---

## Technical specifications

### Charge pump

#### Charge Pump Selection

In most applications a general guideline is that the charge pump displacement should be at least 10% of the total displacement of all components in the system. Unusual application conditions may require a more detailed review of charge flow requirements. System features and conditions which may invalidate the 10% guideline include (but are not limited to):

- Continuous operation at low input speeds < 1500 min<sup>-1</sup> (rpm)
- High shock loading and/or long loop lines
- High flushing flow requirements
- Multiple low speed high torque motors
- High input shaft speeds

Contact your Danfoss representative for application assistance if your application includes any of these conditions.

#### 26/34 cm<sup>3</sup> Charge Pump – Flow and Power Curves

Charge pump flow and power requirements curves shown below at the following conditions:

Charge pressure = 20 bar [290 psi]

Viscosity = 11 mm<sup>2</sup>/s [63 SUS]

Temperature = 80°C [176°F]

Charge pump flow

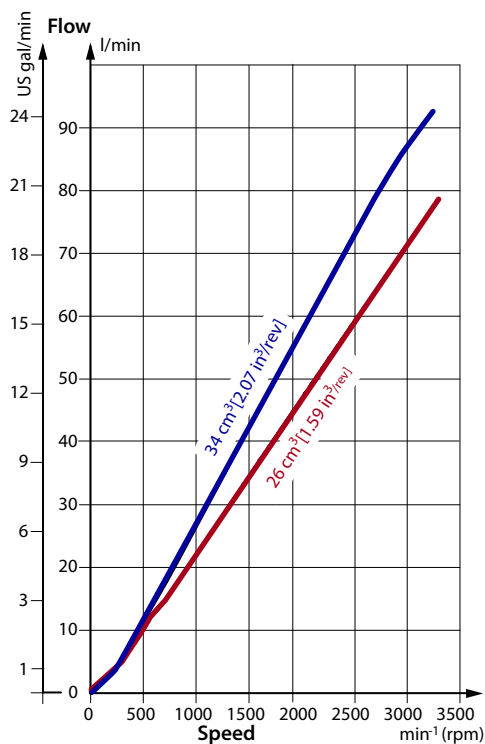

Charge pump power requirements

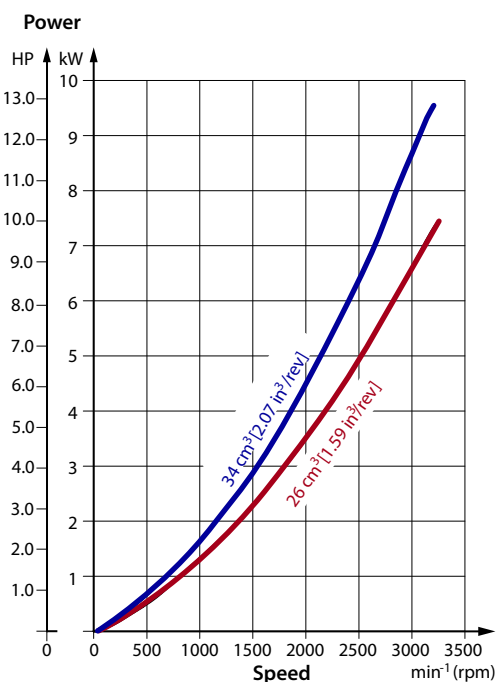

**Master Model Code**

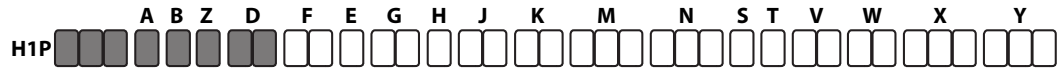

*Displacement*

<b>115</b>	115.2 cm <sup>3</sup> [7.03 in <sup>3</sup> ]
<b>130</b>	130.0 cm <sup>3</sup> [7.93 in <sup>3</sup> ]

*B – Product version*

<b>C</b>	Revision code
----------	---------------





**Master Model Code**

H1P     **A** **B** **Z**   **D**   **F**   **E**   **G**   **H**   **J**   **K**    **M**     **N**     **S**   **T**     **V**     **W**     **X**     **Y**

*H – Mounting (Align with option W – Special hardware features)*

<b>G</b>	ISO 3019-1 flange 152-4 (SAE D)
<b>L</b>	ISO 3019-1 flange 152-4 (SAE D), 4-bolt, with speed sensor

*J – Input shaft*

<b>G2</b>	ISO 3019-1, outer Ø44 mm - 4 (SAE D, 27 teeth splined shaft 16/32 pitch)
<b>G3</b>	ISO 3019-1, outer Ø44 mm - 4 (SAE D, 13 teeth splined shaft 8/16 pitch)
<b>F3</b>	Conical keyed shaft end, code 44-3 (similar to ISO 3019-1), taper 1:8 (key not supplied with pump)

*K – Auxiliary mounting pad per ISO 3019-1*

<b>NN</b>	None
<b>E5</b>	Flange 82-2, outer Ø16 mm - 4 (SAE C, 13 teeth 16/32 coupling); shipping cover
<b>H1</b>	Flange 82-2, outer Ø19 mm - 4 (SAE A, 11 teeth 16/32 coupling); shipping cover
<b>H2</b>	Flange 82-2, outer Ø16 mm - 4 (SAE A, 9 teeth 16/32 coupling); shipping cover
<b>H3</b>	Flange 101-2, outer Ø22 mm - 4 (SAE B, 13 teeth 16/32 coupling); shipping cover
<b>H4</b>	Flange 152-4, outer Ø44 mm - 4 (SAE D, 13 teeth 8/16 coupling); shipping cover
<b>H5</b>	Flange 101-2, outer Ø25 mm - 4 (SAE B-B, 15 teeth 16/32 coupling); shipping cover
<b>H6</b>	Flange 127-4, outer Ø32 mm - 4 (SAE C, 14 teeth 12/24 coupling); shipping cover
<b>S1</b>	Flange 101-2, outer Ø22 mm - 4 (SAE B, 14 teeth 12/24 coupling); shipping cover

Align with option **G – End cap selection**.







## Control Options

### Electrical Displacement Control (EDC)

The Electrical Displacement Control (EDC) consists of a pair of proportional solenoids on each side of a three-position, four-way porting spool. The proportional solenoid applies a force input to the spool, which ports hydraulic pressure to either side of a double acting servo piston.

Differential pressure across the servo piston rotates the swash-plate, changing the pump's displacement from full displacement in one direction to full displacement in the opposite direction. A serviceable 125  $\mu\text{m}$  screen is located in the supply line immediately before the control porting spool.

Under some circumstances, such as contamination, the control spool could stick and cause the pump to stay at some displacement.

*Electrical Displacement Control*

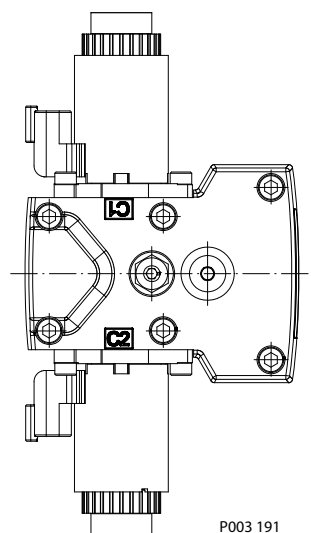

*EDC schematic, feedback from swash-plate*

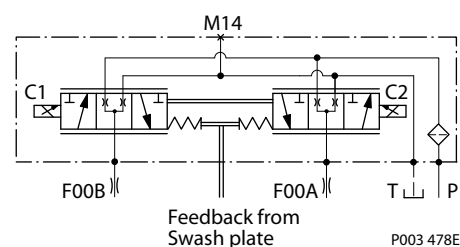

### EDC Control Signal Requirements

*Pump displacement vs. control current*

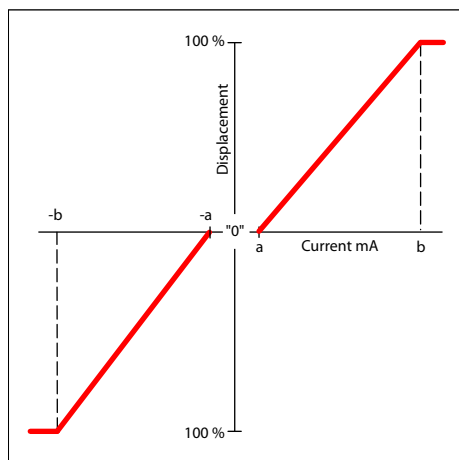

## Control Options

### EDC Control minimum current to stroke pump

Voltage	a*	b	Pin connections
12 V	640 mA	1640 mA	any order
24 V	330 mA	820 mA	

\* Factory test current, for vehicle movement or application actuation expect higher or lower value.

### Connector

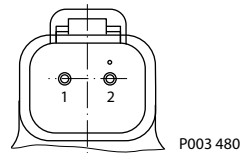

### Connector ordering data

Description	Quantity	Ordering data
Mating connector	1	DEUTSCH DT06-2S
Wedge lock	1	DEUTSCH W2S
Socket contact (16 and 18 AWG)	2	DEUTSCH 0462-201-16141
Danfoss mating connector kit	1	K29657

### EDC Solenoid Data

Description		12 V	24 V
Maximum current		1800 mA	920 mA
Nominal coil resistance	@ 20 °C [68 °F]	3.66 Ω	14.20 Ω
	@ 80 °C [176 °F]	4.52 Ω	17.52 Ω
Inductance		33 mH	140 mH
PWM signal frequency	Range	70 – 100 Hz	
	Recommended*	100 Hz	
IP Rating	IEC 60 529	IP 67	
	DIN 40 050, part 9	IP 69K with mating connector	
Connector color		Black	

\* PWM signal required for optimum control performance.

### Pump output flow direction vs. control signal

Shaft rotation	CW		CCW	
	C1	C2	C1	C2
Coil energized*				
Port A	out	in	in	out
Port B	in	out	out	in
Servo port pressurized	M4	M5	M4	M5

\* For coil location see Installation drawings.

### Control Response

H1 controls are available with optional control passage orifices to assist in matching the rate of swash-plate response to the application requirements. The time required for the pump output flow to change

**Control Options**

from zero to full flow (acceleration) or full flow to zero (deceleration) is a net function of spool porting, orifices, and charge pressure.

H1 pumps are limited in mechanical orifice combinations. Mechanical servo orifices are to be used only for fail-safe return to neutral in a case of an electrical failure.

A swash-plate response times table is available for each frame size. Testing should be conducted to verify the proper orifice selection for the desired response. Typical response times at the following conditions:

$\Delta p = 250 \text{ bar}$  [3626 psi]

Charge pressure = 20 bar [290 psi]

Viscosity and temperature = 30 mm<sup>2</sup>/s [141 SUS] and 50 °C [122 °F]

Speed = 1800 min<sup>-1</sup> (rpm)

**Response Time, EDC 115/130**

<b>Stroking direction</b>	<b>0.8 mm [0.03 in] orifice</b>	<b>1.3 mm [0.05 in] orifice</b>	<b>No orifice</b>
Neutral to full flow	4.4 s	2.0 s	1.0 s
Full flow to neutral	2.9 s	1.3 s	0.8 s

## Control Options

### Manual Displacement Control (MDC)

A Manual proportional Displacement Control (**MDC**) consists of a handle on top of a rotary input shaft. The shaft provides an eccentric connection to a feedback link. This link is connected on its one end with a porting spool. On its other end the link is connected the pumps swash-plate.

This design provides a travel feedback without spring. When turning the shaft the spool moves thus providing hydraulic pressure to either side of a double acting servo piston of the pump.

Differential pressure across the servo piston rotates the swash plate, changing the pump's displacement. Simultaneously the swash-plate movement is fed back to the control spool providing proportionality between shaft rotation on the control and swash-plate rotation.

The MDC changes the pump displacement between no flow and full flow into opposite directions. Under some circumstances, such as contamination, the control spool could stick and cause the pump to stay at some displacement.

A serviceable 125  $\mu\text{m}$  screen is located in the supply line immediately before the control porting spool.

The MDC is sealed by means of a static O-ring between the actuation system and the control block. Its shaft is sealed by means of a special O-ring which is applied for low friction. The special O-ring is protected from dust, water and aggressive liquids or gases by means of a special lip seal.

Manual Displacement Control

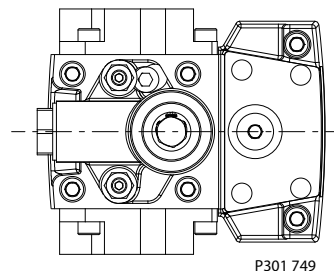

Pump displacement vs. control lever rotation

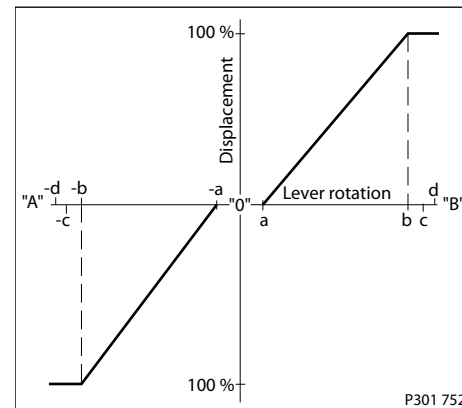

**Legend:**

Deadband on **B** side –  $a = 3^\circ \pm 1^\circ$

Maximum pump stroke –  $b = 30^\circ +2/-1^\circ$

Required customer end stop –  $c = 36^\circ \pm 3^\circ$

Internal end stop –  $d = 40^\circ$

### MDC Torque

Description	Value
Torque required to move handle to maximum displacement	1.4 N·m [12.39 lbf·in]
Torque required to hold handle at given displacement	0.6 N·m [5.31 lbf·in]
Maximum allowable input torque	20 N·m [177 lbf·in]

**⚠ Caution**

Volumetric efficiencies of the system will have impacts on the start and end input commands.

## Control Options

### MDC General Information

In difference to other controls the MDC provides a mechanical deadband. This is required to overcome the tolerances in the mechanical actuation.

The MDC contains an internal end stop to prevent over travel. The restoring moment is appropriate for turning the MDC input shaft back to neutral only. Any linkages or cables may prevent the MDC from returning to neutral.

The MDC is designed for a maximum case pressure of 5 bar and a rated case pressure of 3 bar. If the case pressure exceeds 5 bar there is a risk of an insufficient restoring moment. In addition a high case pressure can cause the NSS to indicate that the control is not in neutral. High case pressure may cause excessive wear.

Customers can apply their own handle design but they must care about a robust clamping connection between their handle and the control shaft and avoid overload of the shaft.

Customers can connect two MDC's on a tandem unit in such a way that the actuation force will be transferred from the pilot control to the second control but the kinematic of the linkages must ensure that either control shaft is protected from torque overload. To avoid an overload of the MDC, customers must install any support to limit the setting range of the Bowden cable.

### Caution

Using the internal spring force on the input shaft is not an appropriate way to return the customer connection linkage to neutral.

### MDC Shaft Rotation

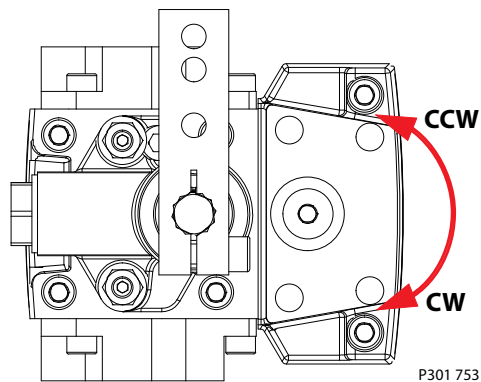

### MDC shaft rotation data

Pump shaft rotation*	Clock Wise (CW)		Counter Clock Wise (CCW)	
	CW	CCW	CW	CCW
Port A	in (low)	out (high)	out (high)	in (low)
Port B	out (high)	in (low)	in (low)	out (high)
Servo port high pressure	M5	M4	M5	M4

\* As seen from shaft side.

## Control Options

### Control Response

H1 controls are available with optional control passage orifices to assist in matching the rate of swash-plate response to the application requirements. The time required for the pump output flow to change from zero to full flow (acceleration) or full flow to zero (deceleration) is a net function of spool porting, orifices, and charge pressure.

**H1 pumps are limited in mechanical orifice combinations. Mechanical servo orifices are to be used only for fail-safe return to neutral in a case of an electrical failure.**

A swash-plate response times table is available for each frame size. Testing should be conducted to verify the proper orifice selection for the desired response. Typical response times at the following conditions:

- $\Delta p = 250 \text{ bar [3626 psi]}$
- Charge pressure = 20 bar [290 psi]
- Viscosity and temperature = 30 mm<sup>2</sup>/s [141 SUS] and 50 °C [122 °F]
- Speed = 1800 min<sup>-1</sup> (rpm)

### MDC Response Time

Code	Orifice description (mm)				Stroking direction (sec)	
	P	A	B	Tank (A+B)	Neutral to full flow	Full flow to neutral
<b>C3</b>	–	–	–	–	0.6	0.7
<b>C6</b>	–	–	–	1	2.2	1.9
<b>C7</b>	–	–	–	1.3	1.4	1.3
<b>D1</b>	1	–	–	0.8	3.9	3.1
<b>D2</b>	1.3	–	–	0.8	3.5	2.8
<b>D3</b>	1.3	–	–	1	2.5	2.0
<b>D4</b>	1.3	1.3	1.3	1	3.0	2.4
<b>D6</b>	1.3	–	–	1.3	1.9	1.5

### Neutral Start Switch (NSS)

The Neutral Start Switch (**NSS**) contains an electrical switch that provides a signal of whether the control is in neutral. The signal in neutral is Normally Closed (**NC**).

*Neutral Start Switch schematic*

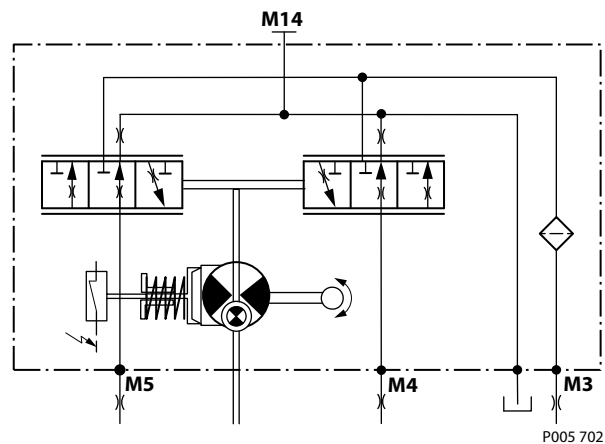

## Control Options

### Neutral Start Switch data

<b>Max. continuous current with switching</b>	8.4 A
<b>Max. continuous current without switching</b>	20 A
<b>Max. voltage</b>	36 V <sub>DC</sub>
<b>Electrical protection class</b>	IP67 / IP69K with mating connector

### Connector

#### Connector

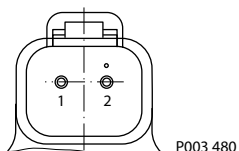

### Connector ordering data

Description	Quantity	Ordering data
Mating connector	1	DEUTSCH DT06-2S
Wedge lock	1	DEUTSCH W2S
Socket contact (16 and 18 AWG)	2	DEUTSCH 0462-201-16141
Danfoss mating connector kit	1	K29657

### Case Gauge Port M14

The drain port should be used when the control is mounted on the unit's bottom side to flush residual contamination out of the control.

#### MDC schematic diagram

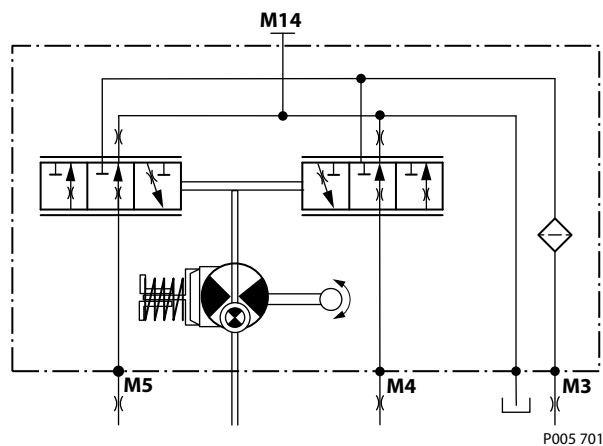

### Lever

MDC-controls are available with an integrated lever.

**Control Options**

**Forward-Neutral-Reverse Electric Control (FNR)**

The 3-position FNR control options **A9** (12 V) and **B1** (24 V) uses an electric input signal to switch the pump to a full stroke position. A serviceable 125 µm screen is located in the supply line immediately before the control porting spool.

*Forward-Neutral-Reverse electric control (FNR)*

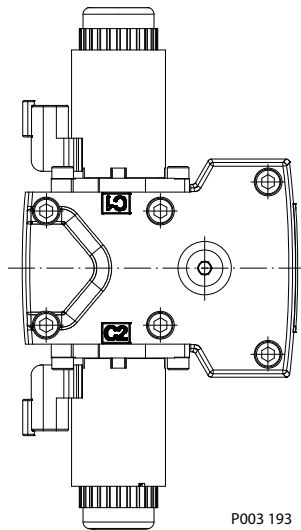

P003 193

*FNR hydraulic schematic*

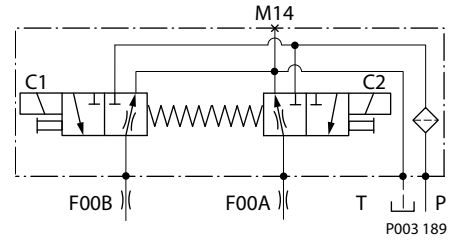

P003 189

*Pump displacement vs. electrical signal*

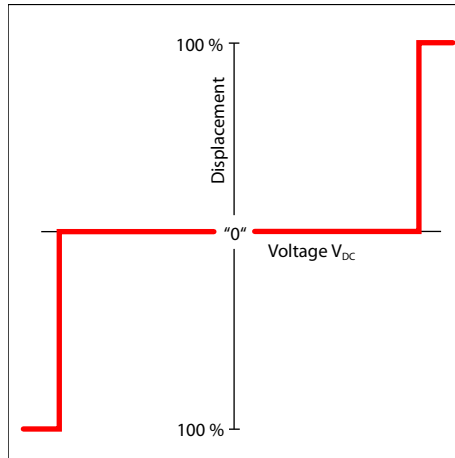

Under some circumstances, such as contamination, the control spool could stick and cause the pump to stay at some displacement.

*Control current*

Voltage	12 V <sub>DC</sub>	24 V <sub>DC</sub>
Min. current to stroke pump	750 mA	380 mA
Pin connections	any order	

## Control Options

### Connector

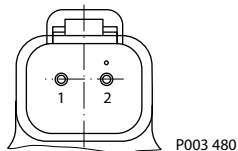

P003 480

#### Connector ordering data

Description	Quantity	Ordering data
Mating connector	1	DEUTSCH DT06-2S
Wedge lock	1	DEUTSCH W2S
Socket contact (16 and 18 AWG)	2	DEUTSCH 0462-201-16141
Danfoss mating connector kit	1	K29657

#### Solenoid data

Voltage	12 V <sub>DC</sub>	24 V <sub>DC</sub>
Minimum supply voltage	9.5 V <sub>DC</sub>	19 V <sub>DC</sub>
Maximum supply voltage (continuous)	14.6 V <sub>DC</sub>	29 V <sub>DC</sub>
Bi-directional diode cut off voltage	28 V <sub>DC</sub>	53 V <sub>DC</sub>
Maximum current	1050 mA	500 mA
Nominal coil resistance @ 20°C	8.4 Ω	34.5 Ω
PWM Range	70-200 Hz	
PWM Frequency (preferred)*	100 Hz	
IP Rating (IEC 60 529) + DIN 40 050	IP 67/IP 69K (part 9 with mating connector)	

\* PWM signal required for optimum control performance.

#### Pump output flow direction vs. control signal

Shaft rotation	CW		CCW	
	C1	C2	C1	C2
Coil energized*				
Port A	in	out	out	in
Port B	out	in	in	out
Servo port pressurized	M5	M4	M5	M4

\* For coil location see [Installation drawings](#) on page 56.

**Control Options**

**Control Response**

H1 controls are available with optional control passage orifices to assist in matching the rate of swash-plate response to the application requirements. The time required for the pump output flow to change from zero to full flow (acceleration) or full flow to zero (deceleration) is a net function of spool porting, orifices, and charge pressure.

H1 pumps are limited in mechanical orifice combinations. Mechanical servo orifices are to be used only for fail-safe return to neutral in a case of an electrical failure.

A swash-plate response times table is available for each frame size. Testing should be conducted to verify the proper orifice selection for the desired response. Typical response times at the following conditions:

$\Delta p = 250 \text{ bar [3626 psi]}$

Charge pressure = 20 bar [290 psi]

Viscosity and temperature = 30 mm<sup>2</sup>/s [141 SUS] and 50 °C [122 °F]

Speed = 1800 min<sup>-1</sup> (rpm)

**Response Time, FNR 115/130**

Stroking direction	0.8 [0.03] orifice	1.3 [0.05] orifice	No orifice
Neutral to full flow	4.2 s	1.9 s	1.2 s
Full flow to neutral	5.2 s	2.2 s	1.1 s

## Control Options

### Non Feedback Proportional Electric Control (NFPE)

The Non Feedback Proportional Electric (**NFPE**) control is an electrical automotive control in which an electrical input signal activates one of two proportional solenoids that port charge pressure to either side of the pump servo cylinder. The NFPE control has no mechanical feedback mechanism.

A serviceable 170  $\mu\text{m}$  screen is located in the supply line immediately before the control porting spool.

Under some circumstances, such as contamination, the control spool could stick and cause the pump to stay at some displacement.

Non Feedback Proportional Electric Control

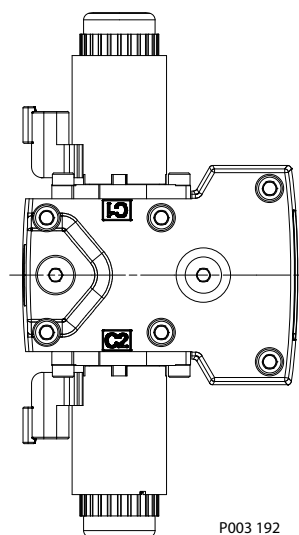

NFPE schematic

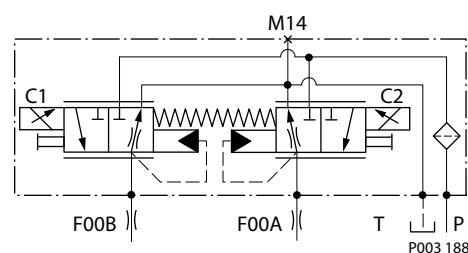

### Control Signal Requirements, NFPE 115/130

The pump displacement is proportional to the solenoid signal current, but it also depends upon pump input speed and system pressure. This characteristic also provides a power limiting function by reducing the pump swash-plate angle as system pressure increases.

A typical response characteristic is shown in the accompanying graph below:

*Pump displacement vs. input signal*

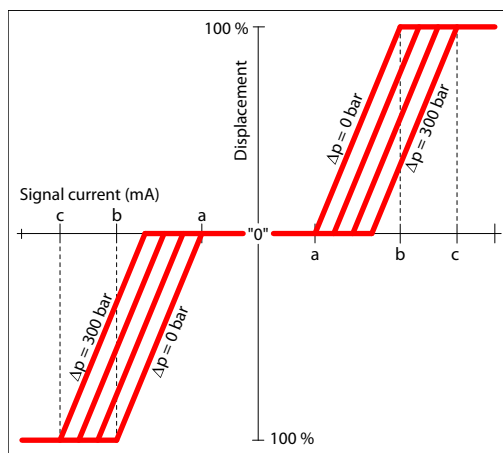

## Control Options

### Control current requirements

Voltage	a*	b	c	Pin connections
12 V	870 mA	1290 mA	1540 mA	any order
24 V	440 mA	670 mA	770 mA	

\* Factory test current, for vehicle movement or application actuation expect higher or lower value.

### Connector

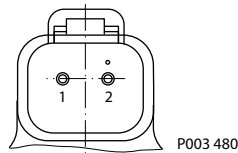

### Connector ordering data

Description	Quantity	Ordering data
Mating connector	1	DEUTSCH DT06-2S
Wedge lock	1	DEUTSCH W2S
Socket contact (16 and 18 AWG)	2	DEUTSCH 0462-201-16141
Danfoss mating connector kit	1	K29657

Description	12 V	24 V
Maximum current	1800 mA	920 mA
Nominal coil resistance	@ 20 °C [68 °F]	3.66 Ω
	@ 80 °C [176 °F]	4.52 Ω
Inductance	33 mH	140 mH
PWM signal frequency	Range	70 – 200 Hz
	Recommended*	200 Hz
IP Rating	IEC 60 529	IP 67
	DIN 40 050, part 9	IP 69K with mating connector
Connector color	Black	

\* PWM signal required for optimum control performance.

### Pump output flow direction vs. control signal

Shaft rotation	CW		CCW	
	C1	C2	C1	C2
Coil energized*				
Port A	in	out	out	in
Port B	out	in	in	out
Servo port pressurized	M5	M4	M5	M4

\* For coil location see Installation drawings.

## Control Options

### Control Response

H1 controls are available with optional control passage orifices to assist in matching the rate of swash-plate response to the application requirements. The time required for the pump output flow to change from zero to full flow (acceleration) or full flow to zero (deceleration) is a net function of spool porting, orifices, and charge pressure.

H1 pumps are limited in mechanical orifice combinations. Mechanical servo orifices are to be used only for fail-safe return to neutral in a case of an electrical failure.

A swash-plate response times table is available for each frame size. Testing should be conducted to verify the proper orifice selection for the desired response. Typical response times at the following conditions:

$\Delta p = 250 \text{ bar}$  [3626 psi]

Charge pressure = 20 bar [290 psi]

Viscosity and temperature = 30 mm<sup>2</sup>/s [141 SUS] and 50 °C [122 °F]

Speed = 1800 min<sup>-1</sup> (rpm)

### NFPE Response Time

Stroking direction	0.8 [0.03] orifice	1.3 [0.05] orifice	No orifice
Neutral to full flow	5.1 s	2.5 s	1.5 s
Full flow to neutral	3.2 s	1.4 s	0.7 s

## Control Options

### Automotive Control (AC)

The H1 **Automotive Control (AC)** is an electric NFPE Control with an integrated microcontroller, installed on the pump. The integrated microcontroller enhanced control performance with a flexible, configurable control scheme for an entire single path propel transmission. It can be used in combination with fixed and variable displacement hydraulic-motors. With the pre-installed application software and easily changeable control parameters, it is possible to tailor the vehicle's driving behavior to the individual requirements of the customer.

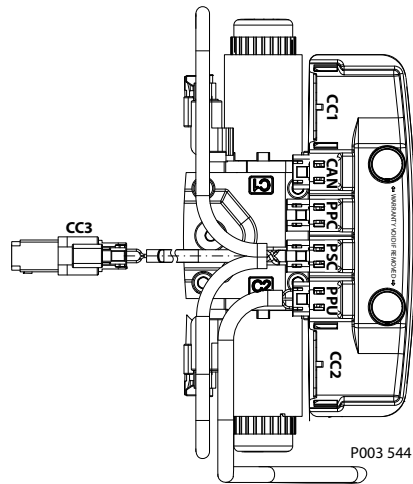

The H1 Automotive Control is divided into 2 systems:

- AC-1
- AC-2

AC-2 is an extension of AC-1 that features an integrated pump swash plate angle sensor and software enabled functions such as Swash Plate Control.

### Mode types

The application software provides 3 different hydrostatic propel methods, defined as mode types, which can be used individually.

- **Automotive Load dependent** (torque controlled) driving behavior. Setpoint for the drive curve is the engine rpm.
- **Non-Automotive Load independent** (speed controlled) driving mode. Setpoint for the drive curve is a Joystick or drive pedal signal, independent of the engine rpm. The best performance will be achieved with an AC-2 Swash Plate Angle Sensor.
- **Creep-Automotive Load dependent** (torque controlled) driving behavior (like Automotive). Setpoint for the drive curve is the engine rpm. The setpoint can be reduced by the creep potentiometer if a high engine rpm in combination with low vehicle speed is needed.

### Basic functions

- Four selectable system modes, selectable via switch.
- Individual settings for forward and reverse driving direction (4 x 2 curves).
- Independent pump and hydraulic-motor profiling and ramping for each mode.
- Electric drive pedal connection
- Electronic inching function without separate control valve
- Electric creep mode potentiometer

## Control Options

- Configurable System Mode & Direction change
- Load independent pump displacement control with integrated Swash Plate Angle Sensor (AC-2)
- Hydraulic-motor displacement control including brake pressure defeat function

### Performance functions

- ECO fuel saving mode with automatic reduction of the engine speed during transport (Cruise control)
- Vehicle constant speed drive control
- Vehicle speed limitation
- Dynamic brake light, automatic park brake, reverse buzzer and status LED outputs
- Vehicle speed controlled output function.
- Temperature compensation for predictable performance
- Advanced CAN J1939 interface for the information exchange with the vehicle control system

### Protection and safety functions

- Safety controlled vehicle start protection with engine speed check, battery check and FNR must be in neutral, etc..
- Operator presence detection
- Hydraulic system overheat and low-temperature protection
- Hydraulic motor over speed protection
- Park brake test mode for roller applications to fulfill SAE J1472 / EN500-4.
- SIL2 compliant

### Engine control and protection

- CAN J1939 engine interface
- Engine speed control via drive pedal with safety controlled monitoring function
- Engine antistall protection
- Engine over speed protection during inching
- Engine speed dependent Retarder control
- Engine cold start protection

### Installation features

- Factory calibration for hysteresis compensation.
- Starting current adjustment in the factory
- Pre-installed application software and parameter files

---

[For more information, see \*Automotive Control for H1 Single Pumps Technical Information\*, BC00000213.](#)

**Control Options**
**Fan Drive Control (FDC)**

The Fan Drive Control (**FDC**) is a non-feedback control in which an electrical input signal activates the proportional solenoid that ports charge pressure to either side of the pump servo cylinder. The single proportional solenoid is used to control pump displacement in the forward or reverse direction.

The control spool is spring biased to produce maximum forward pump displacement in the absence of an electrical input signal. Based on the spring bias spool default forward flow for a CW rotation pump is out of port B while default forward flow for a CCW rotation pump is out of port A.

FDC control

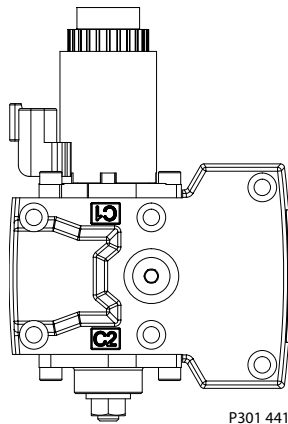

FDC schematic

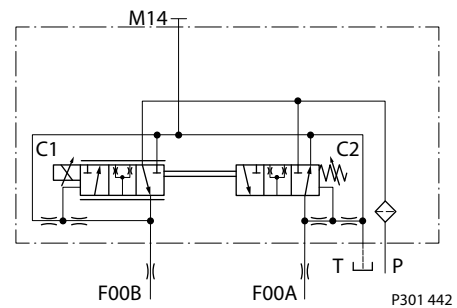

The pump should be configured with 0.8 mm control orifices to provide slowest response and maximize system stability. Additionally, pressure limiter (PL) valves are used to limit maximum fan trim speed in both (forward and reverse) directions.

H1 pumps with FDC will be delivered from factory with nominal pressure limiter setting of 150 bar [2175 psi]. The PL must be re-adjusted to ensure that the fan reaches the desired fan speed to satisfy the cooling needs of the system. HPRV setting must be always at least 30 bar [435 psi] higher than PL setting.

Under some circumstances, such as contamination, the control spool could stick and cause the pump to stay at some displacement.

For more information necessary to properly size and configure a hydraulic fan drive system, see [Hydraulic Fan Drive Design Guidelines AB0000019](#).

Use in other systems could result in unintended movement of the machine or it's elements. Loss of the input signal to this control will cause the pump to produce maximum flow.

The FDC is for Fan Drive systems only!

Due to the fail-safe functionality of the FDC control the pump will stroke to max. displacement in case the input signal to the pump control and the Diesel engine will be switched off at the same time. In this situation a low loop event can occur which may damage the pump. Therefore, it's strictly recommended to keep the input signal to the pump control alive while switching off the engine.

For further information please contact your Danfoss representative.

**Control Signal Requirements, FDC 115/130**

The pump displacement is proportional to the solenoid signal current, but it also depends upon pump input speed and system pressure. This characteristic also provides a power limiting function by reducing the pump swash plate angle as system pressure increases.

A typical response characteristic is shown in the accompanying graph below:

## Control Options

*Pump displacement vs. control current*

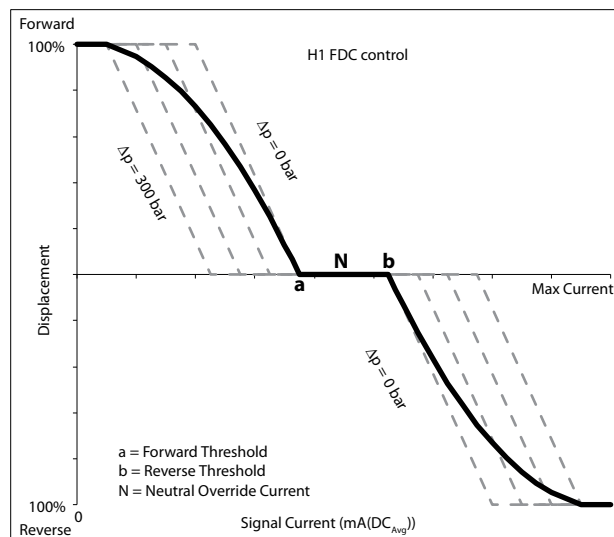

P301 443

*Control current*

Voltage	a*	N	b*	Pin Config
12 V	780 mA	1100 mA	1300 mA	any order
24 V	400 mA	550 mA	680 mA	

\* Factory test current, for fan movement expect higher or lower value.

### Connector

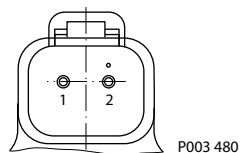

*Connector ordering data*

Description	Quantity	Ordering data
Mating connector	1	DEUTSCH DT06-2S
Wedge lock	1	DEUTSCH W2S
Socket contact (16 and 18 AWG)	2	DEUTSCH 0462-201-16141
Danfoss mating connector kit	1	K29657

Description	12 V	24 V
Maximum current	1800 mA	920 mA
Nominal coil resistance	@ 20 °C [68 °F]	3.66 Ω
	@ 80 °C [176 °F]	4.52 Ω
Inductance	33 mH	140 mH
PWM signal frequency	Range	70 – 200 Hz
	Recommended*	200 Hz

**Control Options**

Description		12 V	24 V
IP Rating	IEC 60 529	IP 67	
	DIN 40 050, part 9	IP 69K with mating connector	
Connector color		Black	

\* PWM signal required for optimum control performance.

*Pump output flow direction vs. control signal*

Shaft rotation		CW			CCW		
Control Logic	12 V	0-780 mA	1100 mA	1300-1800 mA	0-780 mA	1100 mA	1300-1800 mA
	24 V	0-400 mA	550 mA	680-920 mA	0-400 mA	550 mA	680-920 mA
Port A		in	no flow	out	out	no flow	in
Port B		out	no flow	in	in	no flow	out
Servo port pressurized		M5	n/a	M4	M5	n/a	M4

**Warning**

Loss of input signal to the control will cause the pump to produce maximum flow.

**Control Response**

H1 controls are available with optional control passage orifices to assist in matching the rate of swash-plate response to the application requirements. The time required for the pump output flow to change from zero to full flow (acceleration) or full flow to zero (deceleration) is a net function of spool porting, orifices, and charge pressure.

[H1 pumps are limited in mechanical orifice combinations. Mechanical servo orifices are to be used only for fail-safe return to neutral in a case of an electrical failure.](#)

A swash-plate response times table is available for each frame size. Testing should be conducted to verify the proper orifice selection for the desired response. Typical response times at the following conditions:

$\Delta p = 250 \text{ bar}$  [3626 psi]

Charge pressure = 20 bar [290 psi]

Viscosity and temperature = 30 mm<sup>2</sup>/s [141 SUS] and 50 °C [122 °F]

Speed = 1800 min<sup>-1</sup> (rpm)

**Response Time, FDC 115/130**

Stroking direction	0.8 mm [0.03 in] orifice
Full flow to neutral	s
Full forward flow to full reverse flow	s

## Control Options

### Manual Over Ride (MOR)

All controls are available with a Manual Over Ride (MOR) either standard or as an option for temporary actuation of the control to aid in diagnostics.

Forward-Neutral-Reverse (FNR) and Non Feedback Proportional Electric (NFPE) controls are always supplied with MOR functionality.

#### Manual Over Ride (MOR)

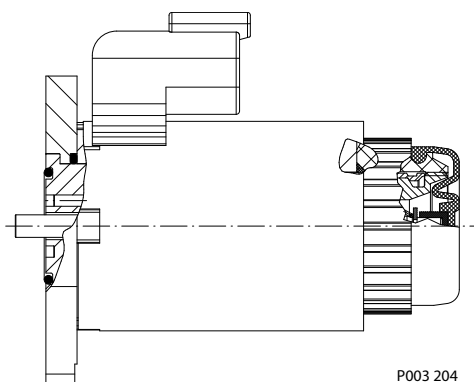

MOR schematic diagram (EDC shown)

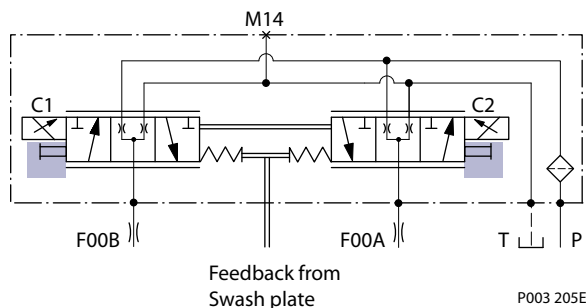

Unintended MOR operation will cause the pump to go into stroke. The vehicle or device must always be in a „safe“ condition when using the MOR function. (Example: vehicle lifted off the ground)

The MOR plunger has a 4 mm diameter and must be manually depressed to be engaged. Depressing the plunger mechanically moves the control spool which allows the pump to go on stroke. The MOR should be engaged anticipating a full stroke response from the pump.

### **Warning**

An o-ring seal is used to seal the MOR plunger where initial actuation of the function will require a force of 45 N to engage the plunger. Additional actuation typically require less force to engage the MOR plunger. Proportional control of the pump using the MOR should not be expected.

Refer to control flow table for the relationship of solenoid to direction of flow.

## Control Options

### Swash Plate Angle Sensor for EDC Controls

The angle sensor detects the swash plate position with an accuracy dependent upon the calibration effort done for the application and direction of rotation from the neutral position. At minimum the sensor can be used for forward, neutral and reverse (FNR) detection.

The sensor works on the hall-effect technology. The implemented technology is based on a measurement of the magnetic field direction in parallel to the chip surface. This field direction is converted to a voltage signal at the output.

Enhanced calibration of the non-linear behavior leads to more exact calculation of the pump swash plate angle.

The 4-pin DEUTSCH connector is part of the sensor housing.

The swash plate angle sensor is available for all EDC controls for 12 V and 24 V.

*Swash plate angle vs. output of supply voltage*

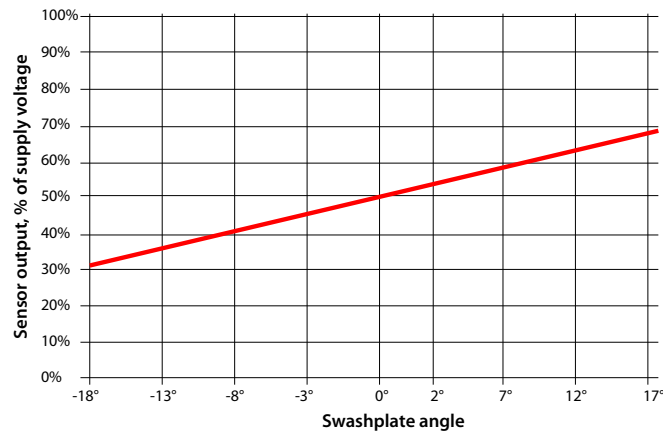

**Strong magnetic fields in the proximity of the sensor can influence the sensor signal and must be avoided.**

[Contact your Danfoss representative in case the angle sensor will be used for safety functions.](#)

### Swash Plate Angle Sensor Parameters (EDC)

Parameter	Minimum	Typical	Maximum
Supply voltage range	4.5 V <sub>DC</sub>	5 V <sub>DC</sub>	5.5 V <sub>DC</sub>
Supply protection	-	-	18 V <sub>DC</sub>
Pump neutral output (% of supply voltage)	-	50%	-
Working range (swash plate angle)	-18°	-	18°
Required supply current	-	-	30 mA
Output current signal	-	9 mA	11 mA
Working temperature	-40°C	80°C	115°C

Protection	Class
IP rating IEC 60 529	IP 67
IP rating DIN 40050, part 9	IP 69K with mating connector
EMC Immunity (ISO 11452-2)	100 V/m

## Control Options

Calibration of the sensor output within the software is mandatory. Vehicle neutral thresholds in the software ( $\pm 0.5^\circ$ ) are vehicle dependent and must consider different conditions, example: system temperature, system pressure and/or shaft speed.

**For safety function:** If the sensor fails (invalid signal  $< 10\%$  or  $> 90\%$  of supply voltage), it must be sure that the ECU will go into a diagnostic mode and shift into limited mode in order for the driver to take the full control or the mechanical breaks should be activated.

Strong magnetic fields in the proximity of the sensor can influence the sensor signal and must be avoided.

### Swash Plate Angle Sensor Connector

DEUTSCH 4-pin connector

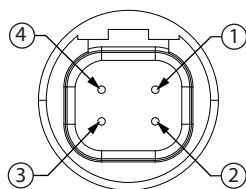

Legend:

1. Ground (GND)
2. Not connected
3. Output signal 1 (SIG 1)
4. Supply (V+)

Connector order numbers

Description	Quantity	Order number
Mating connector DTM06-4S-E004	1	<b>11105824</b>
Wedge lock WM-4S	1	not available
Socket contact 0462-201-2031	3	

### Interface with ECU

Interface with ECU diagram

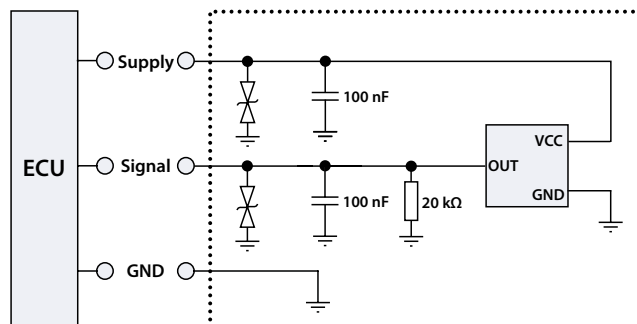

## Control Options

### Swash plate angle sensor for NFPE and AC2 controls

The angle sensor detects the swash plate angle position and direction of rotation from the zero position. The swash angle sensor works on the AMR sensing technology. Under the saturated magnetic field, the resistance of the element varies with the magnetic field direction.

The output signal give a linear output voltage for the various magnet positions in the sensing range.

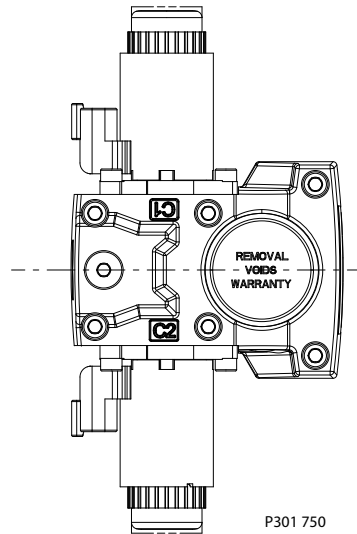

Swash plate angle vs. output voltage

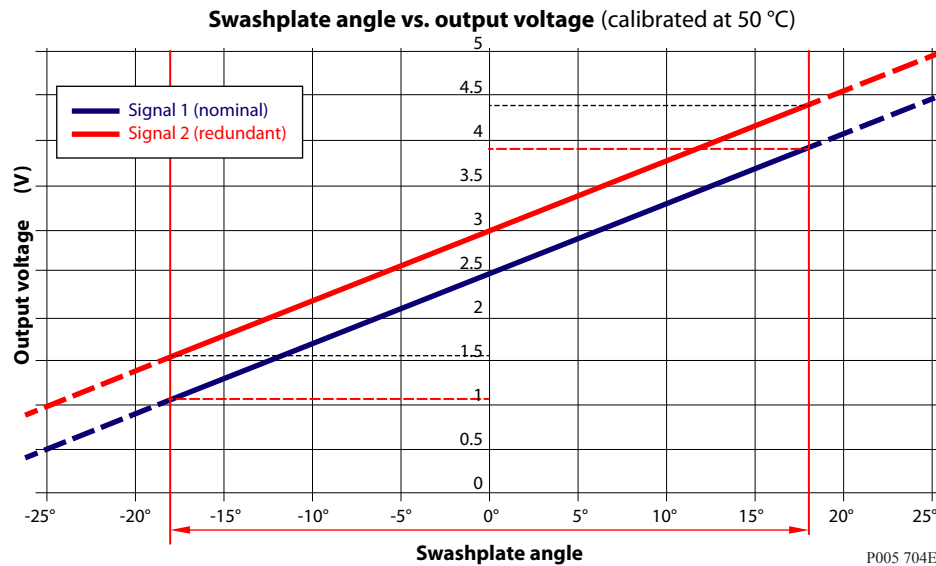

### Swash Plate Angle Sensor Parameters (NFPE/AC)

Parameter	Minimum	Typical	Maximum
Supply voltage range	4.75 V	5 V	5.25 V
Supply protection	–	–	28 V
Supply current	–	22 mA	25 mA
Output current (Signal 1, 2)	–	0.1 mA	–
Short circuit output current to supply or GND <sup>1)</sup>	–	–	7.5 mA

## Control Options

Parameter	Minimum	Typical	Maximum
<b>Sensitivity</b>	70.0 mV/deg	78.0 mV/deg	85.8 mV/deg
<b>Working range (swash plate angle)</b>	-18°	0°	18°
<b>Correlation between signals 1 and 2<sup>2)</sup></b>	475 mV	500 mV	525 mV

<sup>1)</sup> Up to duration of 2.5 seconds at 25°C

<sup>2)</sup> Signal 1 (nominal) is lower than signal 2 (redundant)

### Swash Plate Angle Sensor Connector

DEUTSCH 4-pin connector

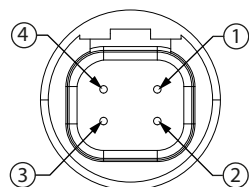

4-Pin Legend:

1. Ground (GND)
2. Output Signal 2 (SIG2) – Secondary (redundant)
3. Output Signal 1 (SIG1) – Primary (nominal)
4. Supply (V+)

Connector order numbers

Description	Quantity	Order number
Mating connector DTM06-4S-E004	1	<b>11105824</b>
Wedge lock W4S	1	<b>11084558</b>
Socket contact (16-18 AWG) 0462-201-16141	2	<b>K02325</b>

### Interface with ECU

Interface with ECU schematic

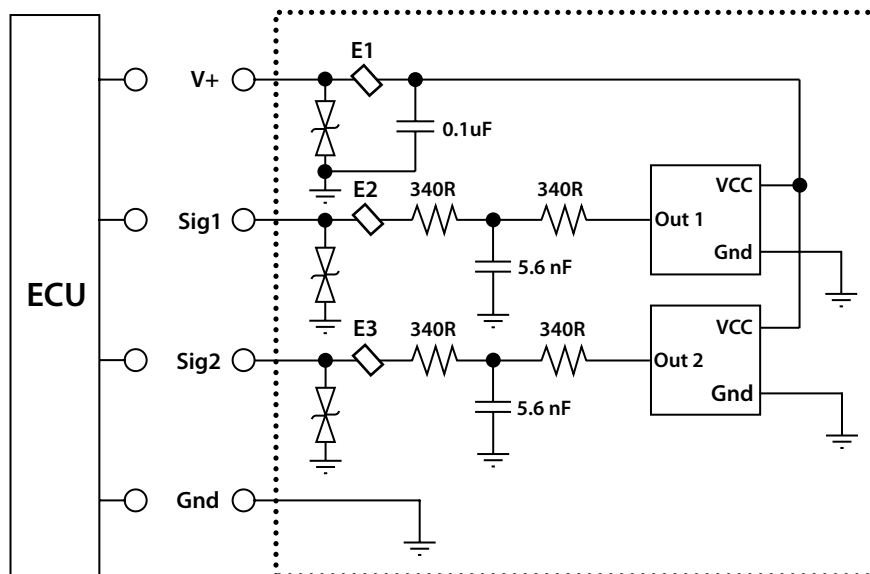

Minimum recommended load resistance is 100 kΩ.

## Control Options

### Control-Cut-Off valve (CCO valve)

The H1 pump offers an optional control cut off valve integrated into the control. This valve will block charge pressure to the control, allowing the servo springs to de-stroke both pumps regardless of the pump's primary control input. There is also a hydraulic logic port, X7, which can be used to control other machine functions, such as spring applied pressure release brakes. The pressure at X7 is controlled by the control cut off solenoid. The X7 port would remain plugged if not needed.

In the normal (de-energized) state of the solenoid charge flow is prevented from reaching the controls. At the same time the control passages and the X7 logic port are connected and drained to the pump case. The pump will remain in neutral, or return to neutral, independent of the control input signal. Return to neutral time will be dependent on oil viscosity, pump speed, swashplate angle, and system pressure.

When the solenoid is energized, charge flow and pressure is allowed to reach the pump control. The X7 logic port will also be connected to charge pressure and flow.

The solenoid control is intended to be independent of the primary pump control making the control cut off an override control feature. It is however recommended that the control logic of the CCO valve be maintained such that the primary pump control signal is also disabled whenever the CCO valve is de-energized. Other control logic conditions may also be considered.

All EDC and MDC controls are available with a CCO valve. The CCO-valve is available with 12 V or 24 V solenoid.

The response time of the unit depends on the control type and the used control orifices.

*CCO schematic (MDC shown)*

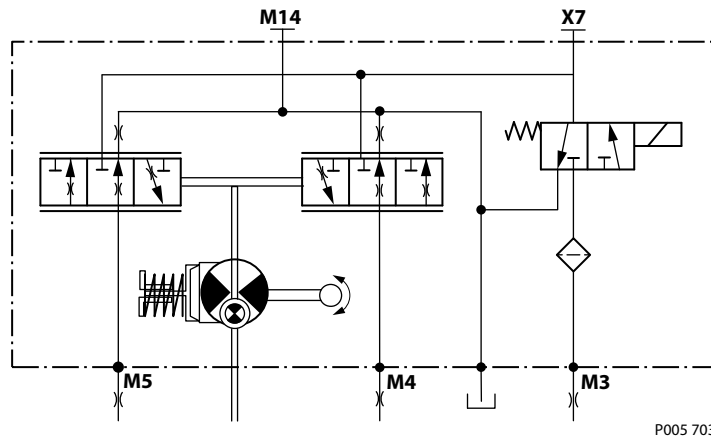

### CCO connector

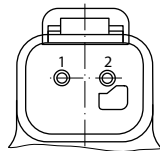

#### Connector ordering data

Description	Quantity	Ordering number
Mating connector	1	DEUTSCH DT06-2S
Wedge lock	1	DEUTSCH W2S
Socket contact (16 and 18 AWG)	2	DEUTSCH 0462-201-16141

## Control Options

### CCO solenoid data

Nominal supply voltage		12 V	24 V
Supply voltage	Maximum	14.6 V	29 V
	Minimum	9.5 V	19 V
Nominal coil resistance at 20°C		10.7 Ω	41.7 Ω
Supply current	Maximum	850 mA	430 mA
	Minimum	580 mA	300 mA
PWM frequency	Range	50-200 Hz	50-200 Hz
	Preferred	100 Hz	100 Hz
Electrical protection class		IP67 / IP69K with mating connector	
Bi-directional diode cut off voltage		28 V	53 V

### Brake gauge port with MDC

**!** **Caution**

It is not recommended to use brake port for any external flow consumption to avoid malfunction of CCO function.

## Displacement limiter

H1 pumps are designed with optional mechanical displacement (stroke) limiters factory set to max. displacement. The maximum displacement of the pump can be set independently for forward and reverse using the two adjustment screws to mechanically limit the travel of the servo piston down to 50 % displacement.

Adjustments under operating conditions may cause leakage. The adjustment screw can be completely removed from the threaded bore if backed out to far.

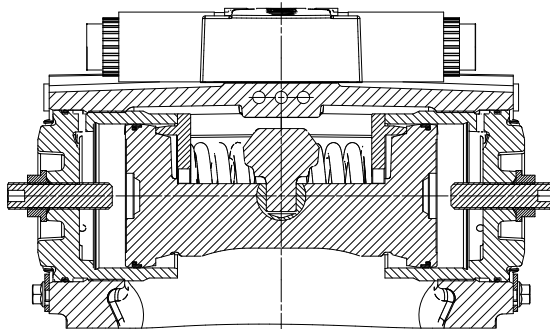

P003 266

### H1P 115/130 Displacement Change (Approximately)

Parameter	Size 115	Size 130
1 Turn of displacement limiter screw	10.8 cm <sup>3</sup> [0.66 in <sup>3</sup> ]	12.2 cm <sup>3</sup> [0.74 in <sup>3</sup> ]
Internal wrench size	6 mm	
External wrench size	22 mm	
Torque for external hex seal lock nut	80 N·m [708 lbf·in]	

For more information, see *H1 Axial Piston Pumps, Service Manual*, **AX00000087**, the section "Displacement Limiter Adjustment".



**Dimensions**

**H1P input shaft - Option G2 (SAE D, 27 teeth)**

*Option G2, ISO 3019-1, outer dia 44 mm-4 (SAE E, 27 teeth)*

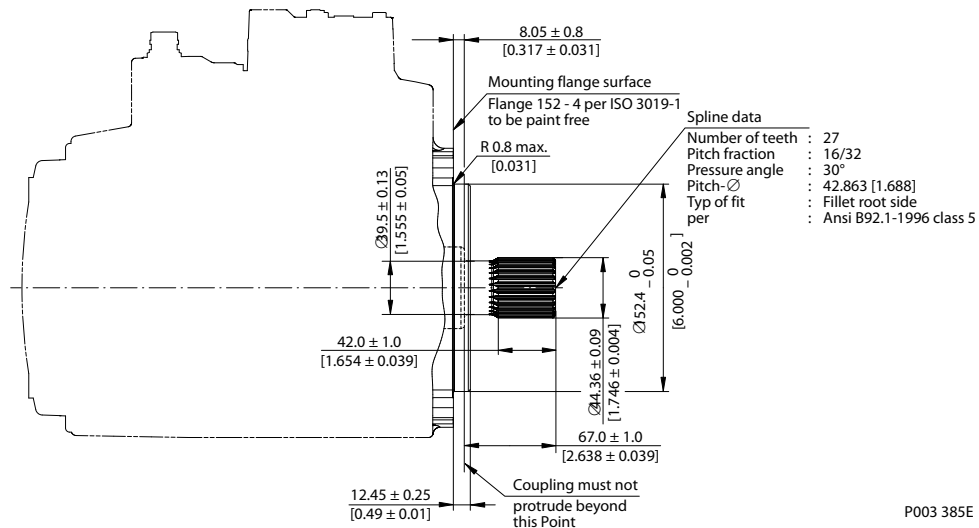

*Specifications*

Option		G2
Spline		27 teeth, 16/32 pitch
Min. active spline length for the specified torque ratings		42.0 mm [1.654 in]
Torque rating	Rated	1615 N·m [14 300 lbf·in]
	Maximum	3000 N·m [26 550 lbf·in]

For definitions of maximum and rated torque values, refer to *H1 Axial Piston Pumps Basic Information, BC00000057*, the section “Shaft Torque Ratings and Spline Lubrication”.

**Dimensions**

**H1P input shaft - Option F3, Code 44-3**

Option F3, ISO 3019-1, Code 44-3, Diameter 44.5 taper 1:8, without key and no through-hole in the end of the shaft

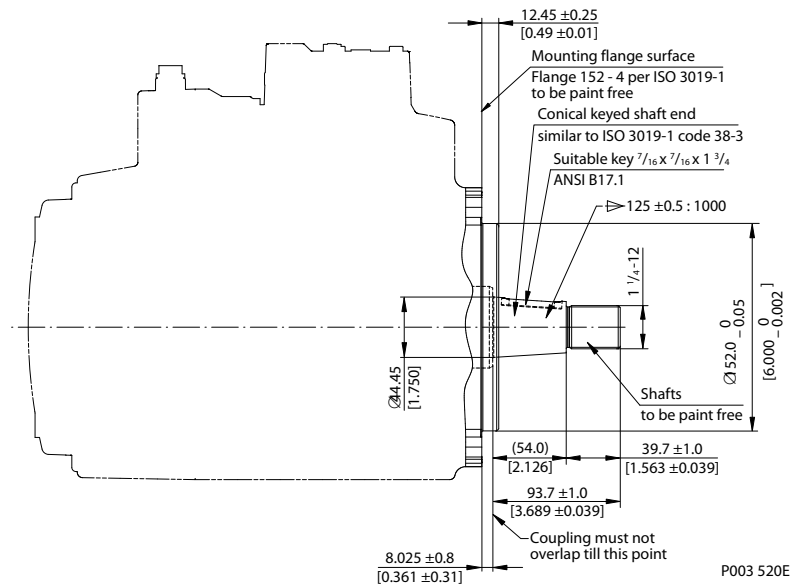

*Specifications*

Option	F3	
Tapered shaft	44-3 taper without key	
Torque rating	Rated	1766 N·m [15 630 lbf·in]
	Maximum	2354 N·m [20 830 lbf·in]

Mating part must maintain a minimum gap width of 1.0 mm with the shaft shoulder after installation of the part. Transmittable torque will be reduced if the minimum gap requirement is not met.

Rated torque includes just the capability of the press-fit in accordance with an assumed fastener grade 5.

[For definitions of maximum and rated torque values, refer to H1 Axial Piston Pumps Basic Information, BC0000057, the section "Shaft Torque Ratings and Spline Lubrication".](#)

## Dimensions

### **Tapered shaft customer acknowledgement**

The Danfoss H1 tapered shaft has been designed using the industry standard ISO 3019-1, minus the through-hole in the end of the shaft. Danfoss recommends a self-locking nut instead of a castle nut and pin. The nut and mating square-cut key are customer supplied. The specified torque rating of the tapered shaft is based on the cross-sectional diameter of the shaft, through the keyway, and assumes the proper clamp and fit between shaft and coupling.

Danfoss guarantees the design and manufactured quality of the tapered shaft. The customer is responsible for the design and manufactured quality of the mating female coupling and key and applied torque on the nut. Danfoss has made provisions for the key in accordance to the ISO specification with the understanding that the key is solely to assist in the installation of the mating coupling.

### **Caution**

---

Possible hazard because torque or loading inadvertently transmitted by the customer supplied key may lead to premature shaft failure.

Torque must be transmitted by the taper fit between the shaft and it's mating coupling, not the key.

---

**Dimensions**

**H1P 115/130 Auxiliary mounting - Option H1 (SAE A, 11 teeth)**

Option H1, ISO 3019-1, flange 82-2 (SAE A, 11 teeth)

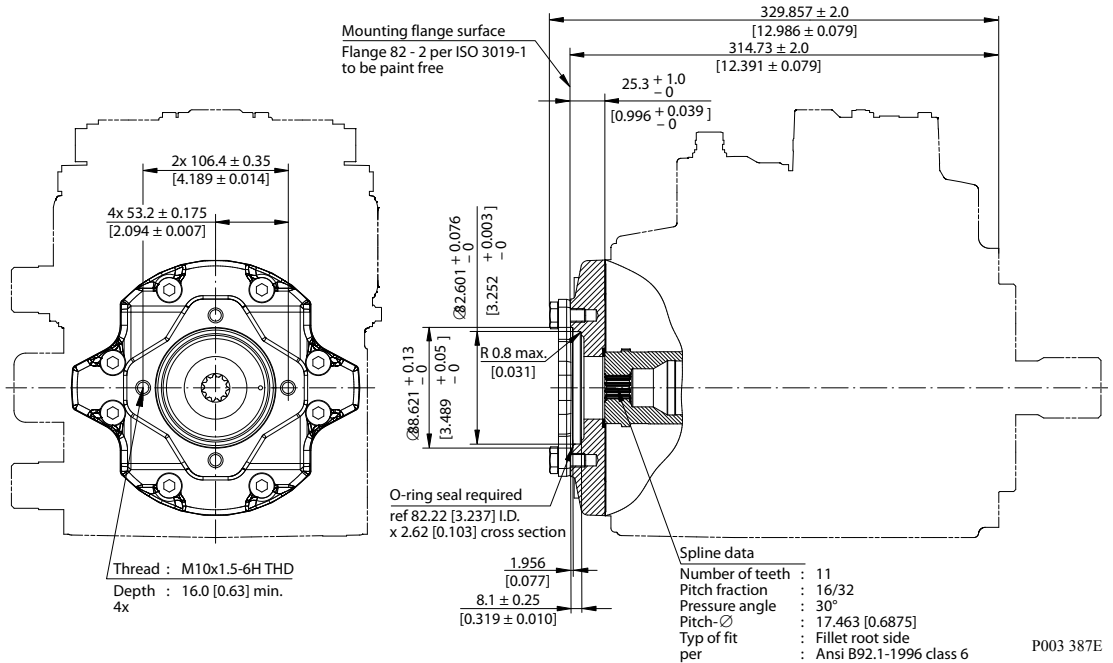

*Specifications*

<b>Option</b>	<b>H1</b>
<b>Spline</b>	11 teeth, 16/32 pitch
<b>Maximum torque</b>	296 N•m [2620 lbf•in]

For definitions of maximum and rated torque values, refer to *H1 Axial Piston Pumps Basic Information, BC0000057*, the section “Shaft Torque Ratings and Spline Lubrication”.

**! Caution**

Standard pad cover is installed only to retain coupling during shipping. Do not operate pump without an auxiliary pump or running cover installed.

**Dimensions**

**H1P 115/130 Auxiliary mounting - Option H2 (SAE A, 9 teeth)**

Option H2, ISO 3019-1, flange 82-2 (SAE A, 9 teeth)

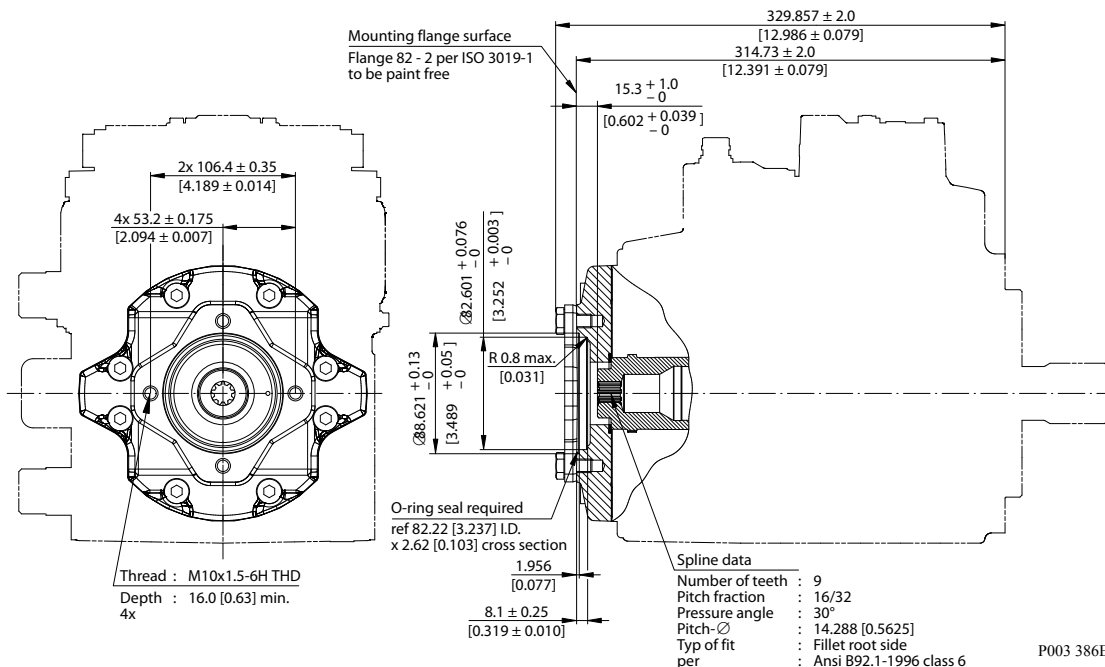

*Specifications*

<b>Option</b>	<b>H2</b>
<b>Spline</b>	9 teeth, 16/32 pitch
<b>Maximum torque</b>	162 N·m [1430 lbf·in]

For definitions of maximum and rated torque values, refer to *H1 Axial Piston Pumps Basic Information, BC0000057*, the section “Shaft Torque Ratings and Spline Lubrication”.

**! Caution**

Standard pad cover is installed only to retain coupling during shipping. Do not operate pump without an auxiliary pump or running cover installed.

**Dimensions**

**H1P 115/130 Auxiliary mounting - Option H3 (SAE B, 13 teeth)**

Option H3, ISO 3019-1, flange 101-2 (SAE B, 13 teeth)

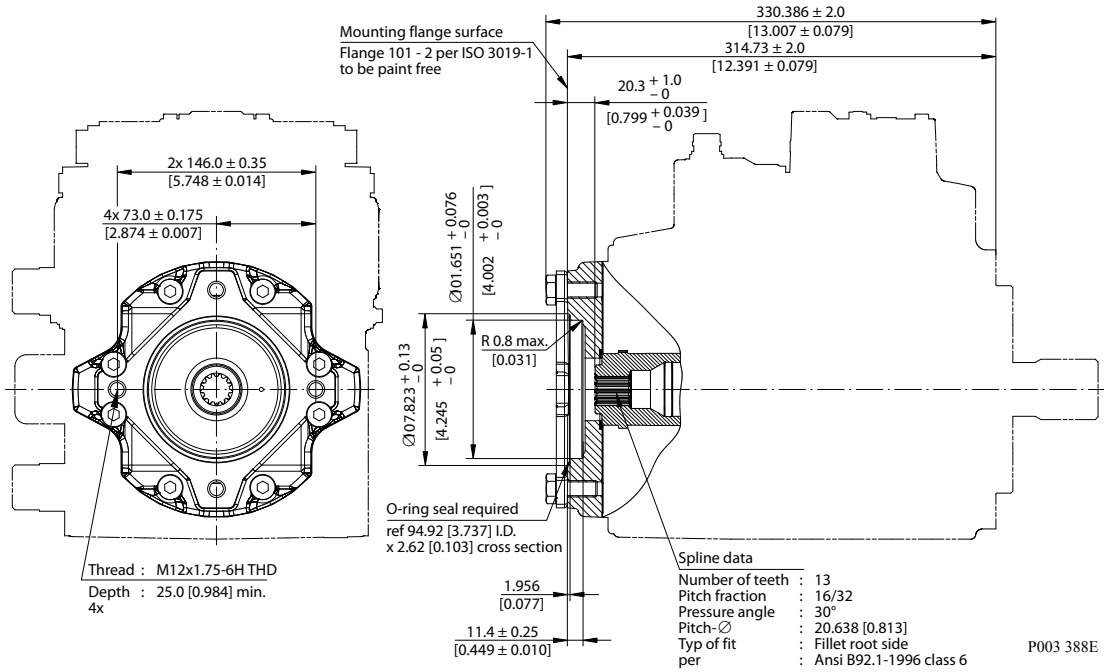

*Specifications*

<b>Option</b>	<b>H3</b>
<b>Spline</b>	13 teeth, 16/32 pitch
<b>Maximum torque</b>	395 N•m [3500 lbf•in]

For definitions of maximum and rated torque values, refer to *H1 Axial Piston Pumps Basic Information, BC00000057*, the section “Shaft Torque Ratings and Spline Lubrication”.

**! Caution**

Standard pad cover is installed only to retain coupling during shipping. Do not operate pump without an auxiliary pump or running cover installed.

**Dimensions**
**H1P 115/130 Auxiliary mounting - Option H4 (SAE D, 13 teeth)**

Option H4, ISO 3019-1, flange 152-4 (SAE D, 13 teeth)

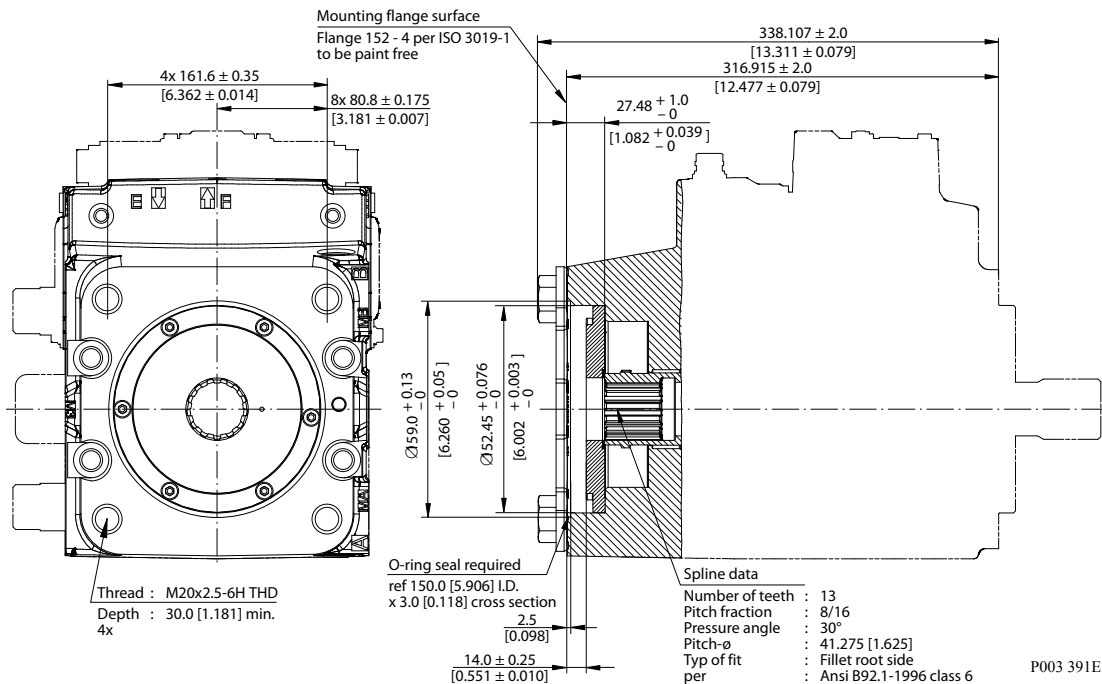
**Specifications**

<b>Option</b>	<b>H4</b>
<b>Spline</b>	13 teeth, 8/16 pitch
<b>Maximum torque</b>	2206 N•m [19 525 lbf•in]

For definitions of maximum and rated torque values, refer to *H1 Axial Piston Pumps Basic Information, BC0000057*, the section "Shaft Torque Ratings and Spline Lubrication".

**Caution**

Standard pad cover is installed only to retain coupling during shipping. Do not operate pump without an auxiliary pump or running cover installed.

**Dimensions**

**H1P 115/130 Auxiliary mounting - Option H5 (SAE B-B, 15 teeth)**

Option H5, ISO 3019-1, flange 101-2 (SAE B-B, 15 teeth)

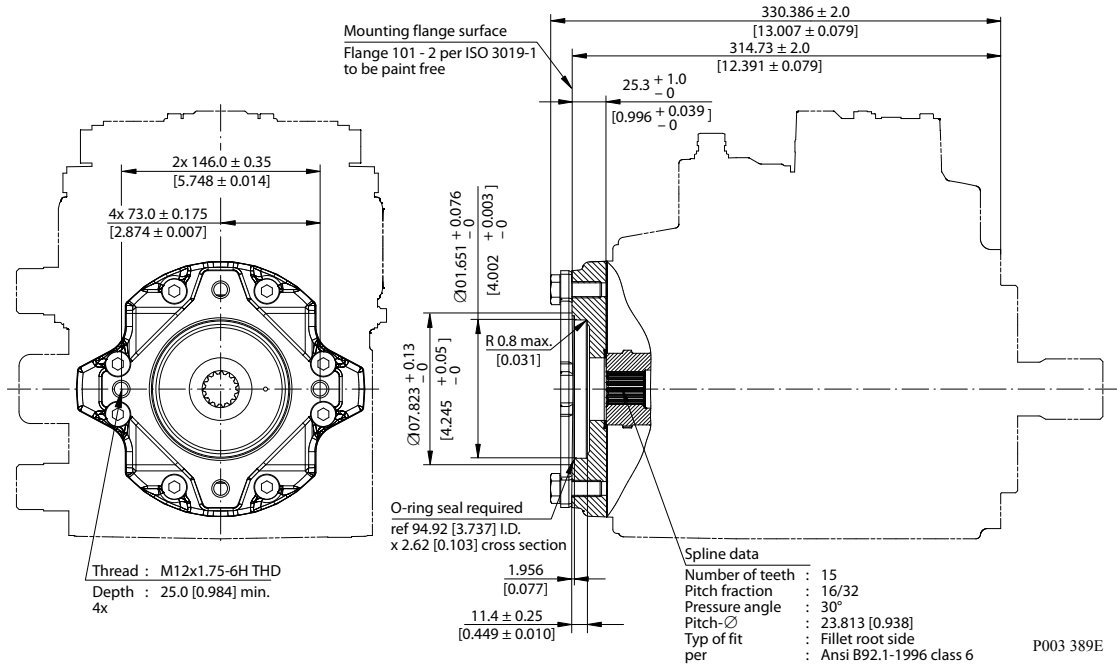

*Specifications*

<b>Option</b>	<b>H5</b>
<b>Spline</b>	15 teeth, 16/32 pitch
<b>Maximum torque</b>	693 N•m [6130 lbf•in]

For definitions of maximum and rated torque values, refer to *H1 Axial Piston Pumps Basic Information, BC0000057*, the section “Shaft Torque Ratings and Spline Lubrication”.

**! Caution**

Standard pad cover is installed only to retain coupling during shipping. Do not operate pump without an auxiliary pump or running cover installed.



**Dimensions**

**H1P 115/130 Auxiliary mounting - Option S1 (SAE B-B, 14 teeth)**

*Option S1, ISO 3019-1, flange 101-2 (SAE B, 14 teeth, special)*

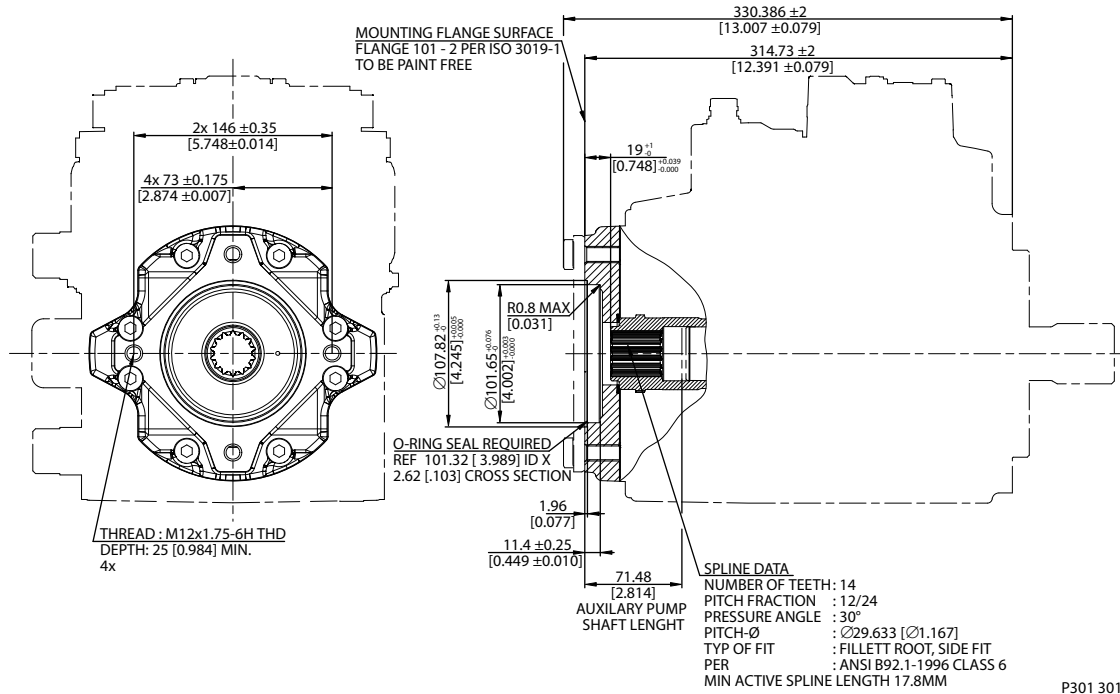

*Specifications*

<b>Option</b>	<b>S1</b>
<b>Spline</b>	14 teeth, 12/24 pitch
<b>Maximum torque</b>	816 N•m [7220 lbf•in]

For definitions of maximum and rated torque values, refer to *H1 Axial Piston Pumps Basic Information, BC0000057*, the section "Shaft Torque Ratings and Spline Lubrication".

**! Caution**

Standard pad cover is installed only to retain coupling during shipping. Do not operate pump without an auxiliary pump or running cover installed.

### Dimensions

#### H1P 115/130 displacement limiter, option B and D

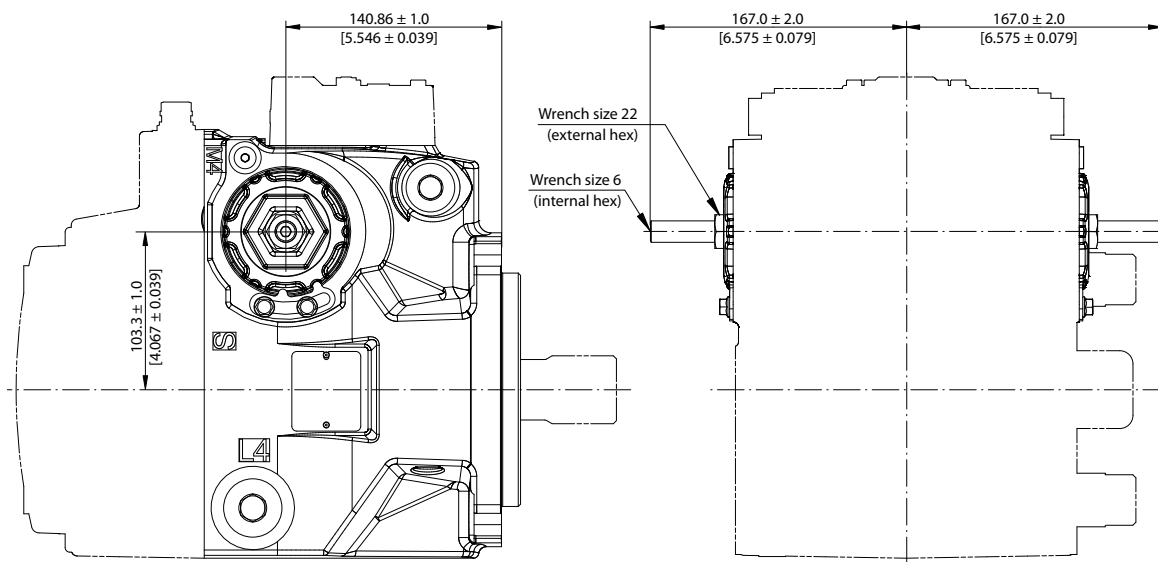

P003 401E

[Please contact Danfoss representative for specific installation drawings.](#)

**Installation drawings**

**Port Description H1P115/130**

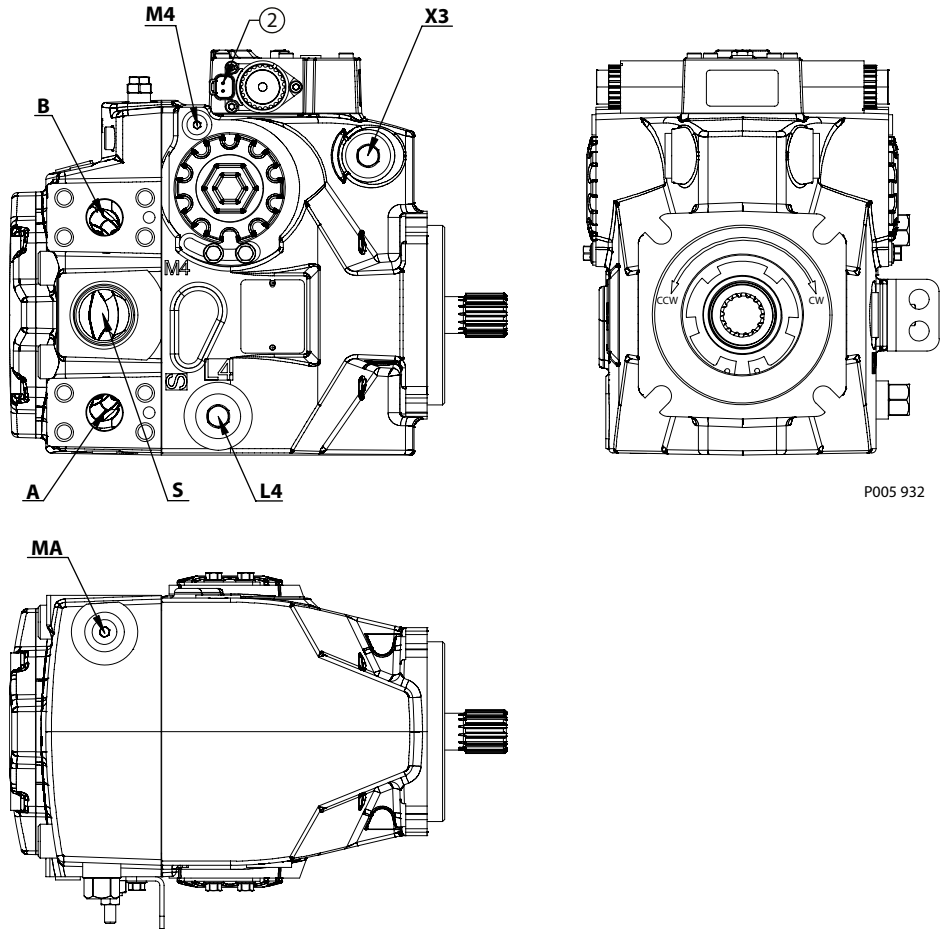

*Ports per ISO 11926-1 description*

Port	Description	Size 115/130
<b>A, B</b>	System ports <b>A</b> and <b>B</b> 450 bar, Split flange boss per ISO 6162	Ø31.5 mm; M12 x 1.75; 20 min. full thread depth Recommended screw in depth 1.5 x thread dia
<b>MA</b>	System <b>A</b> gauge port	$\frac{9}{16}$ -18; Ø28 max clearance dia for fitting
<b>X3</b>	Case pressure port	$1\frac{1}{16}$ -12; Ø41 max clearance dia for fitting
<b>L4</b>	Case drain port	$1\frac{5}{16}$ -12; Ø63 max clearance dia for fitting
<b>M4</b>	Servo gauge port	$\frac{7}{16}$ -20; Ø24.5 max clearance dia for fitting
<b>S</b>	Charge inlet port	$1\frac{5}{8}$ -12 max clearance dia for fitting

Please contact Danfoss representative for specific installation drawings.

**Installation drawings**

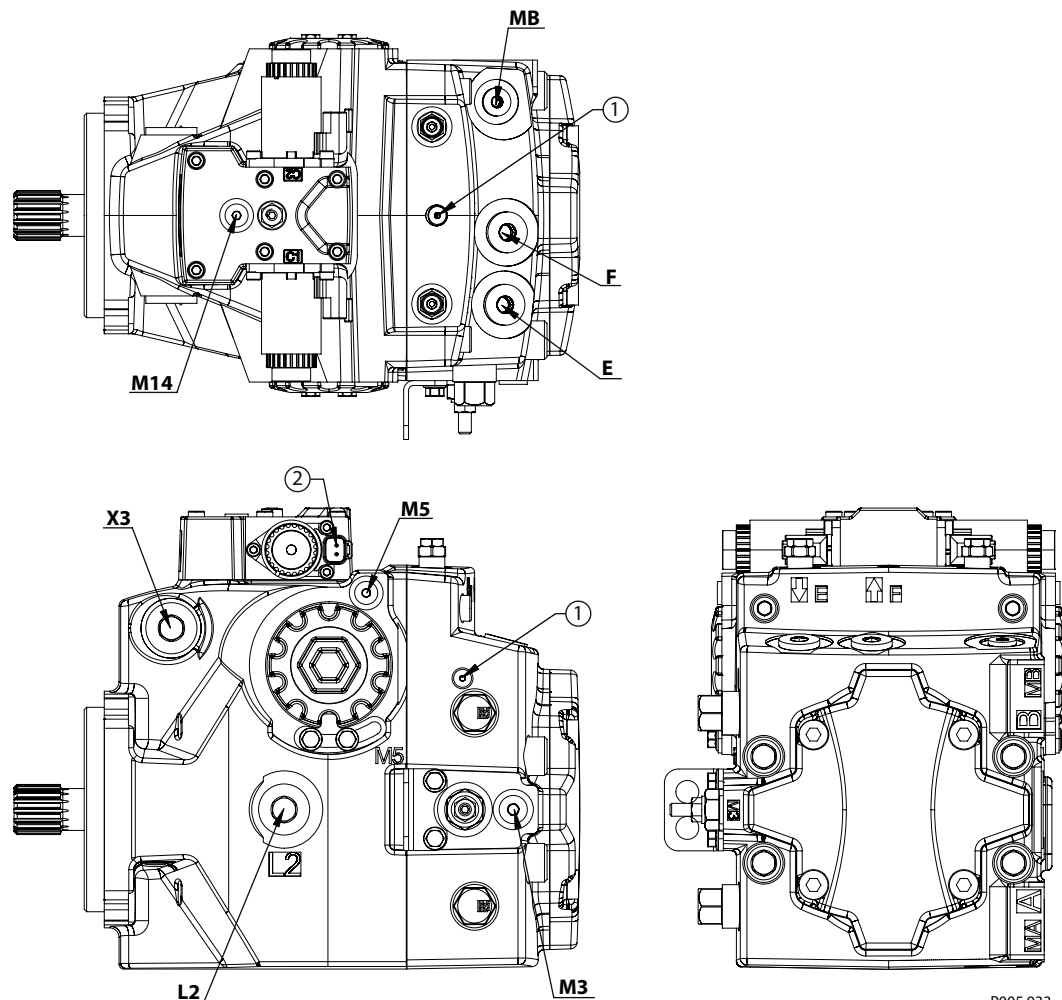

P005 933

1. Charge pressure construction port  $\frac{5}{16}$ -24
2. Connector (Deutsch DT04-2P) to be paint free

*Ports per ISO 11926-1 description*

Port	Description	Size 115/130
<b>E, F</b>	Charge filtration port from/to filter	$1\frac{1}{16}$ -12 $\varnothing$ 42 max clearance dia for fitting
<b>L2</b>	Case drain port	$1\frac{5}{16}$ -12; $\varnothing$ 63 max clearance dia for fitting
<b>X3</b>	Case pressure port	$1\frac{1}{16}$ -12; $\varnothing$ 41 max clearance dia for fitting
<b>MB</b>	System <b>B</b> gauge port	$\frac{9}{16}$ -18; $\varnothing$ 28 max clearance dia for fitting
<b>M3</b>	Charge gauge port, after filtering	$\frac{9}{16}$ -18; $\varnothing$ 28 max clearance dia for fitting
<b>M5 / M14</b>	Servo / Case gauge port	$\frac{7}{16}$ -20; $\varnothing$ 21 max clearance dia for fitting

[Please contact Danfoss representative for specific installation drawings.](#)

**Installation drawings**

**Dimensions H1P 115/130**

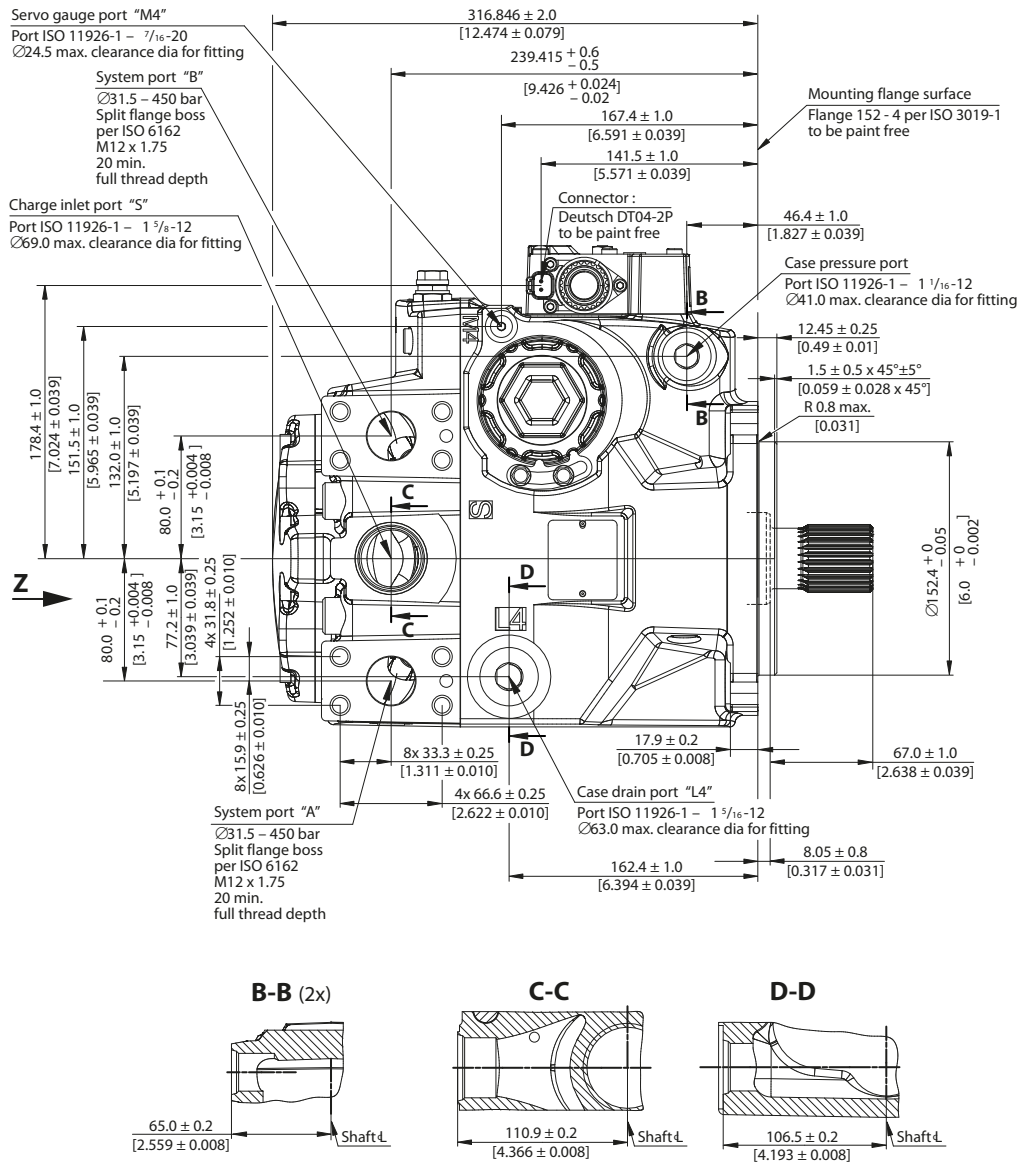

P003 394E

Please contact Danfoss representative for specific installation drawings.

Technical Information  
**H1P 115/130 Axial Piston Single Pumps**

**Installation drawings**

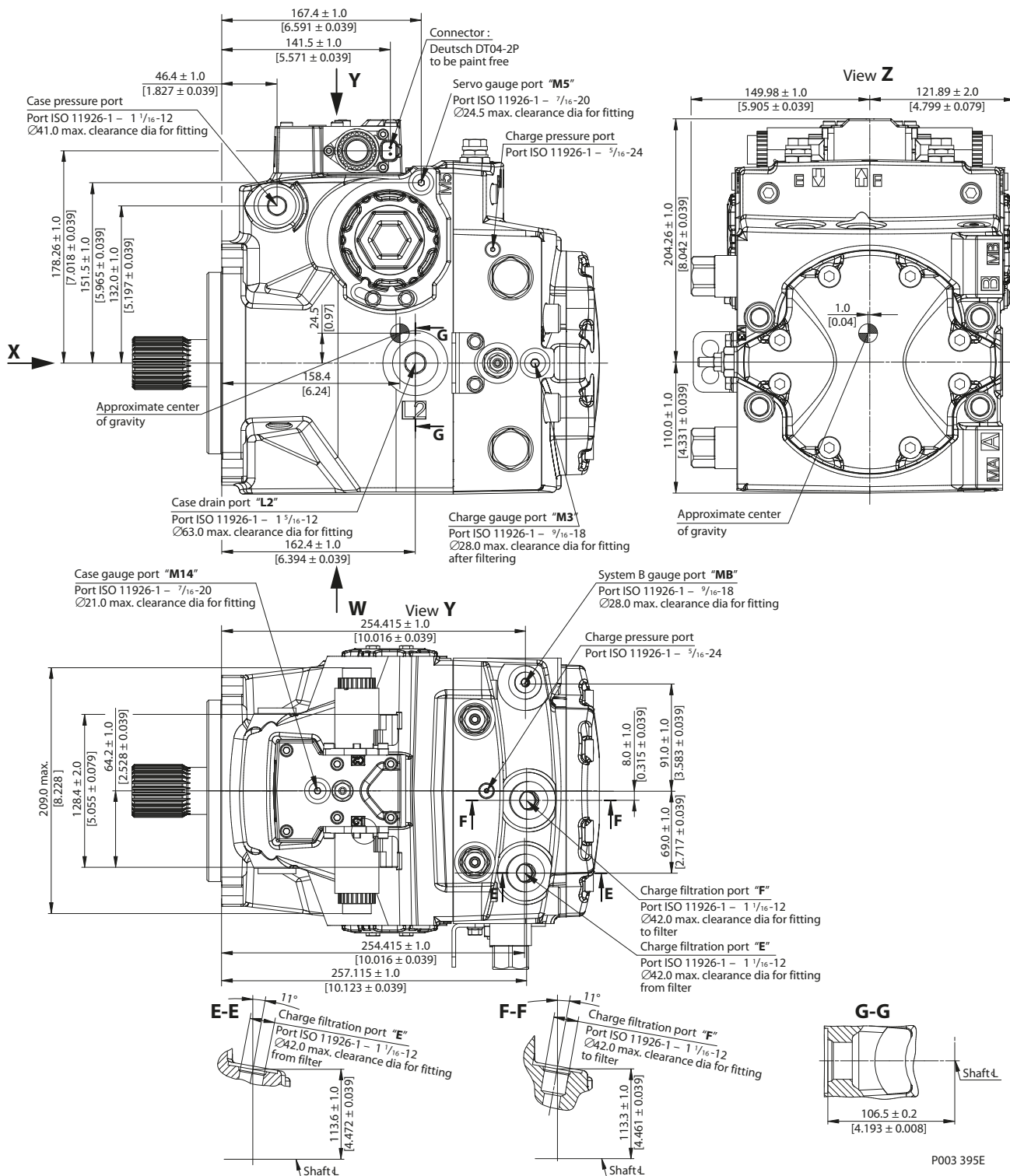

Please contact Danfoss representative for specific installation drawings.



**Controls**

**Electric Displacement Control (EDC), option A2 (12 V) / A3 (24 V)**

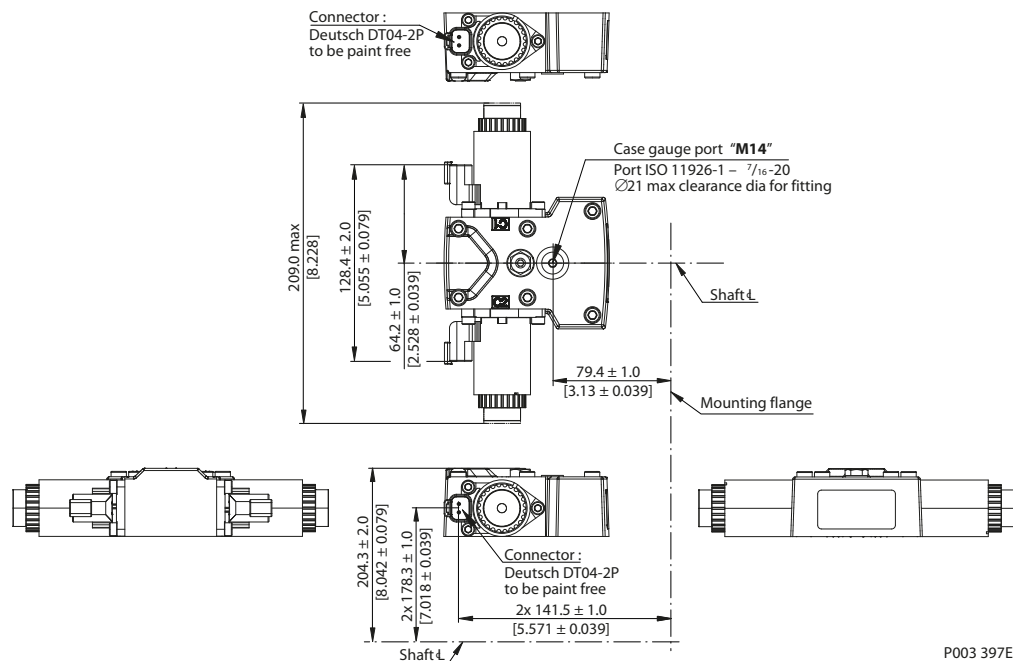

**Electric Displacement Control (EDC) with MOR, options A4 (12 V) / A5 (24 V)**

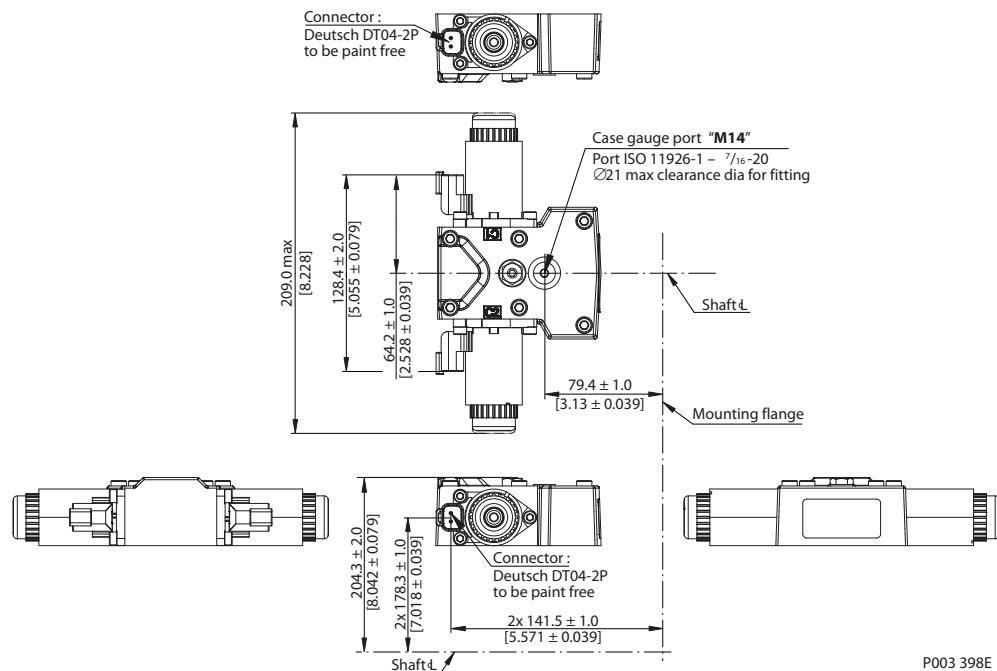

Please contact Danfoss representative for specific installation drawings.

**Controls**

**H1P 115/130 Manual Displacement Control (MDC), option M1**

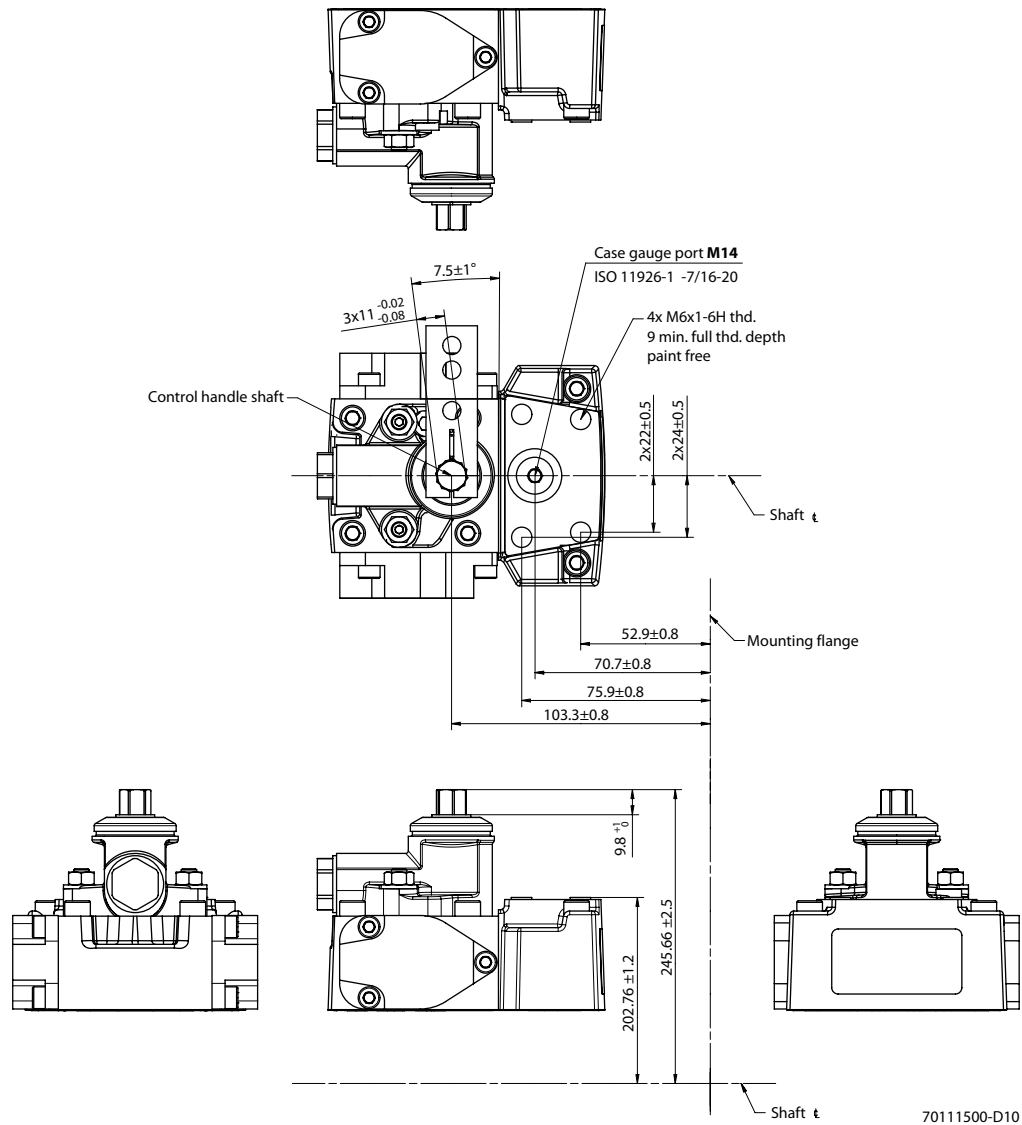

Please contact Danfoss representative for specific installation drawings.

**Controls**

**H1P 115/130 Manual Displacement Control (MDC) with NSS, option M2**

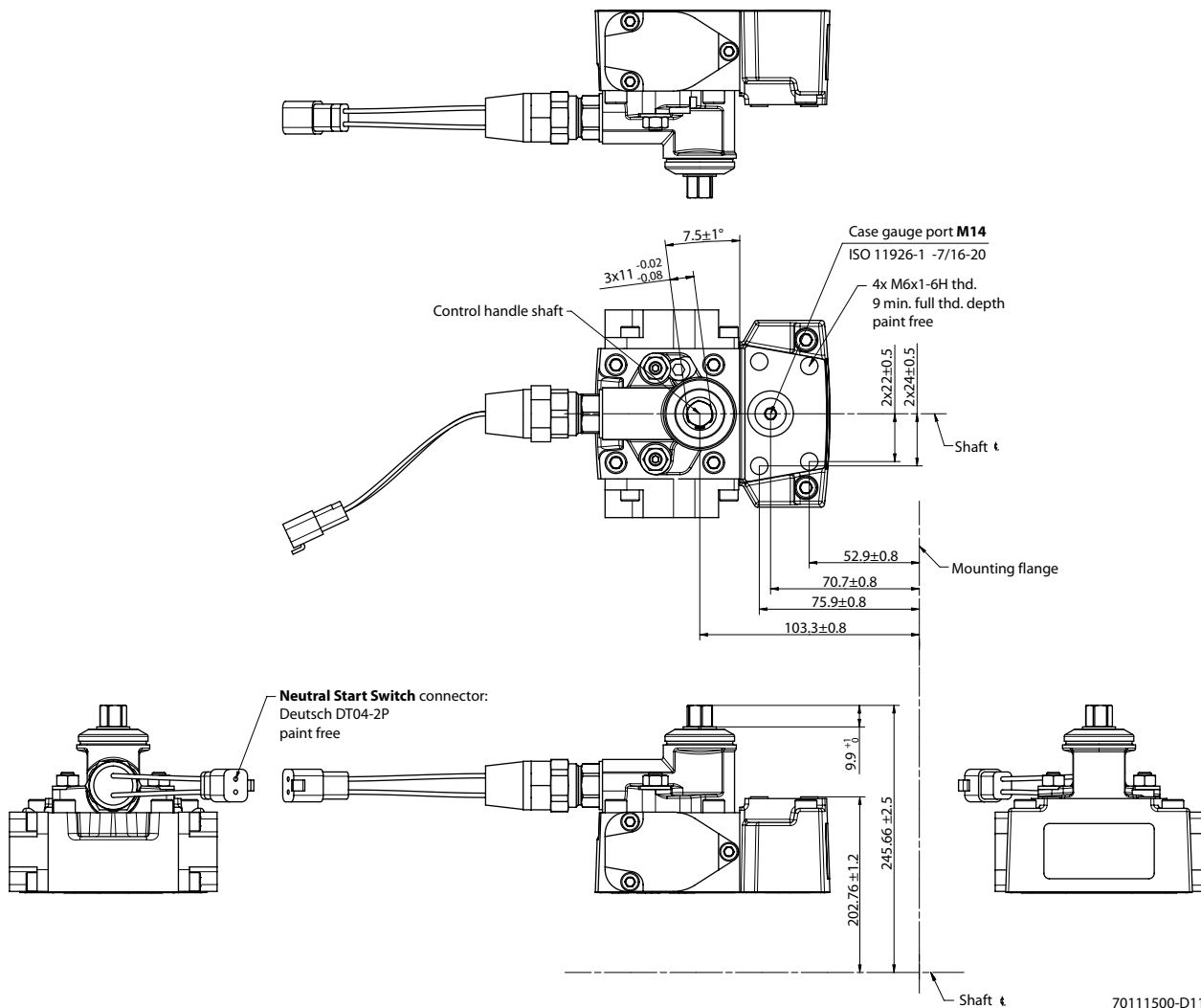

Neutral Start Switch connector:

Pin	Assignment		Pin	Assignment
1	Supply	OR	1	Ground
2	Ground		2	Supply

[Please contact Danfoss representative for specific installation drawings.](#)

**Controls**

**H1P 115/130 Manual Displacement Control (MDC) with CCO, option M3, M4**

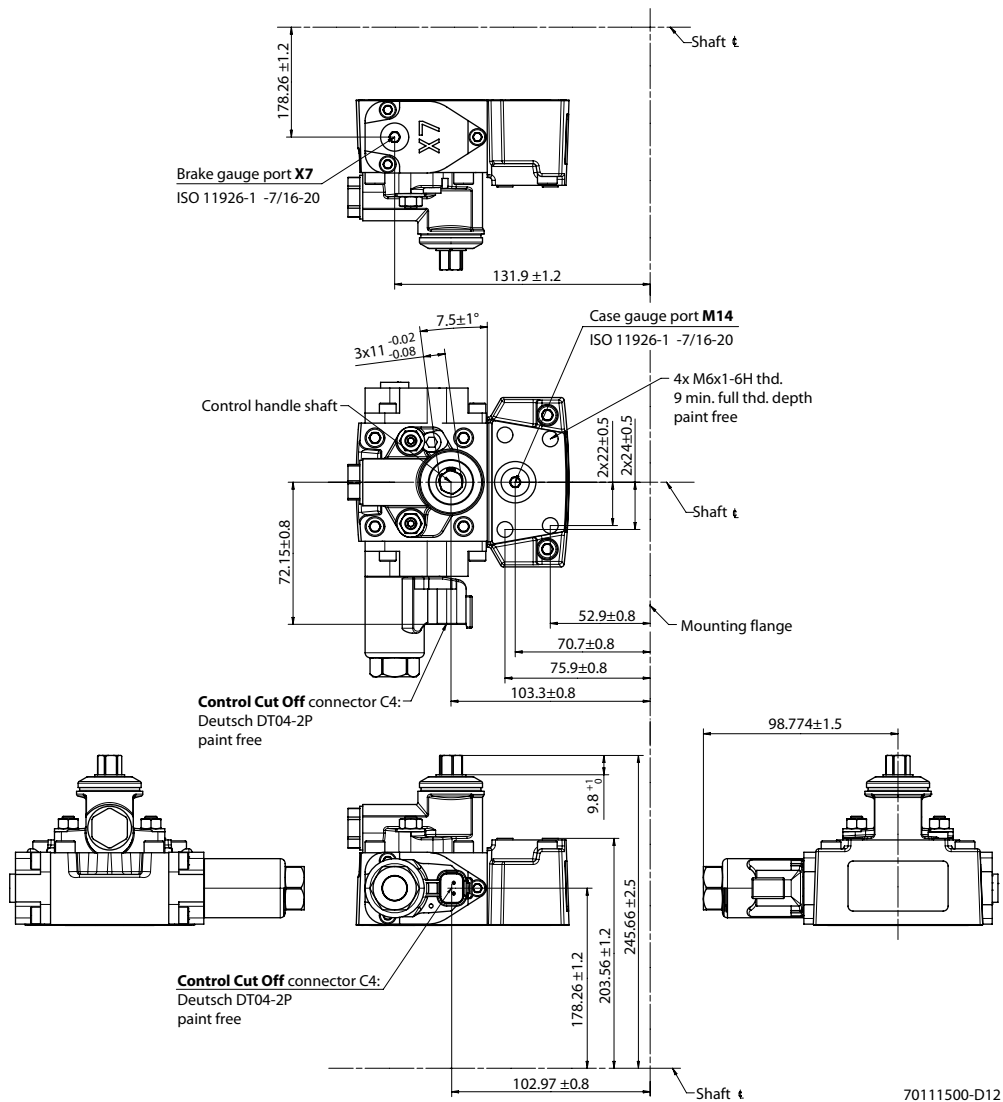

*Control Cut Off connector C4:*

Pin	Assignment		Pin	Assignment
1	Supply	OR	1	Ground
2	Ground		2	Supply

Please contact Danfoss representative for specific installation drawings.

**Controls**

**H1P 115/130 Manual Displacement Control (MDC) with NSS and CCO, option M5, M6**

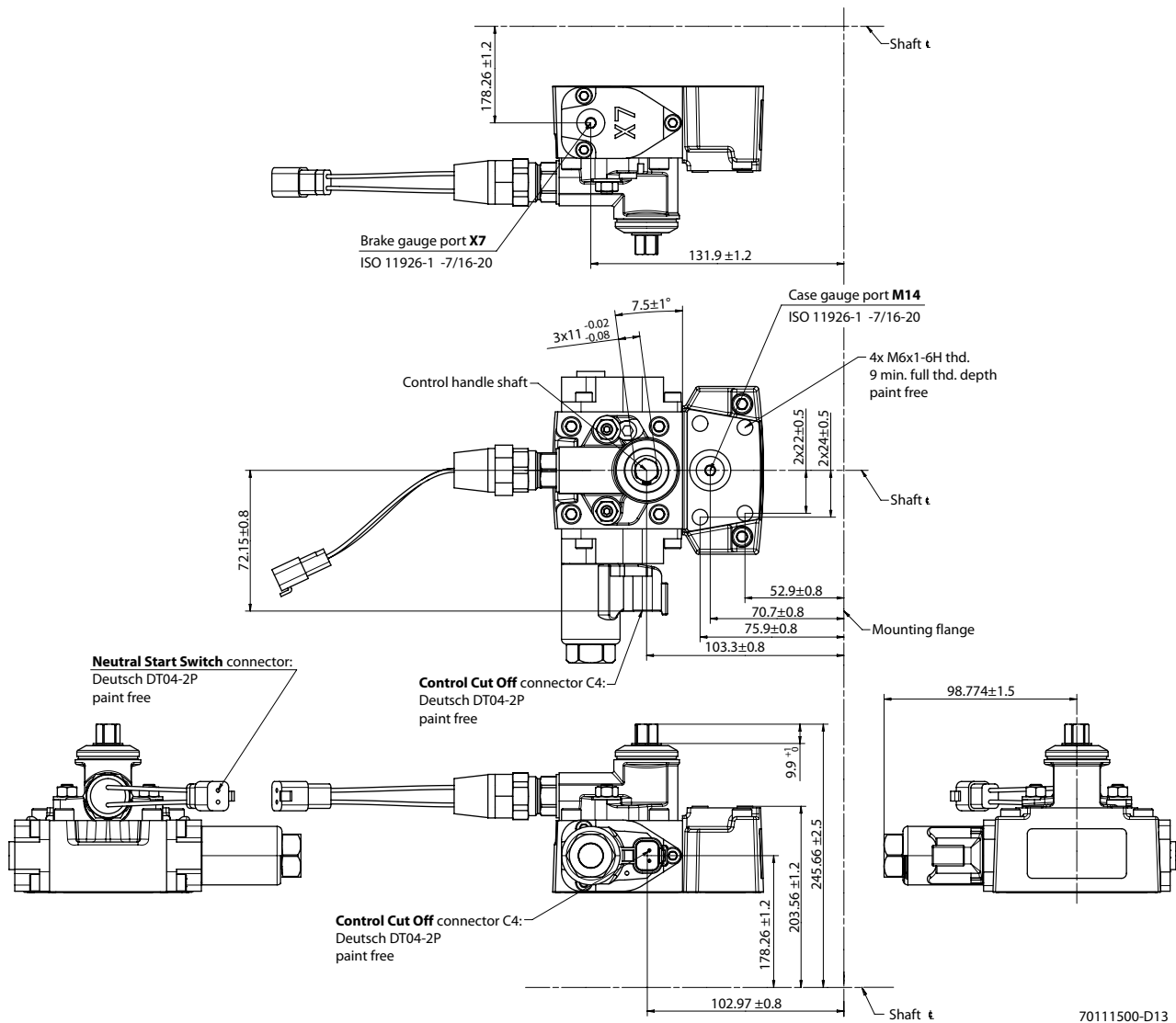

Neutral Start Switch connector / Control Cut Off connector C4:

Pin	Assignment		Pin	Assignment
1	Supply	OR	1	Ground
2	Ground		2	Supply

Please contact Danfoss representative for specific installation drawings.

**Controls**

**Non Feedback Proportional Electric control (NFPE), with manual override, option A8 (12 V) / B8 (24 V)**

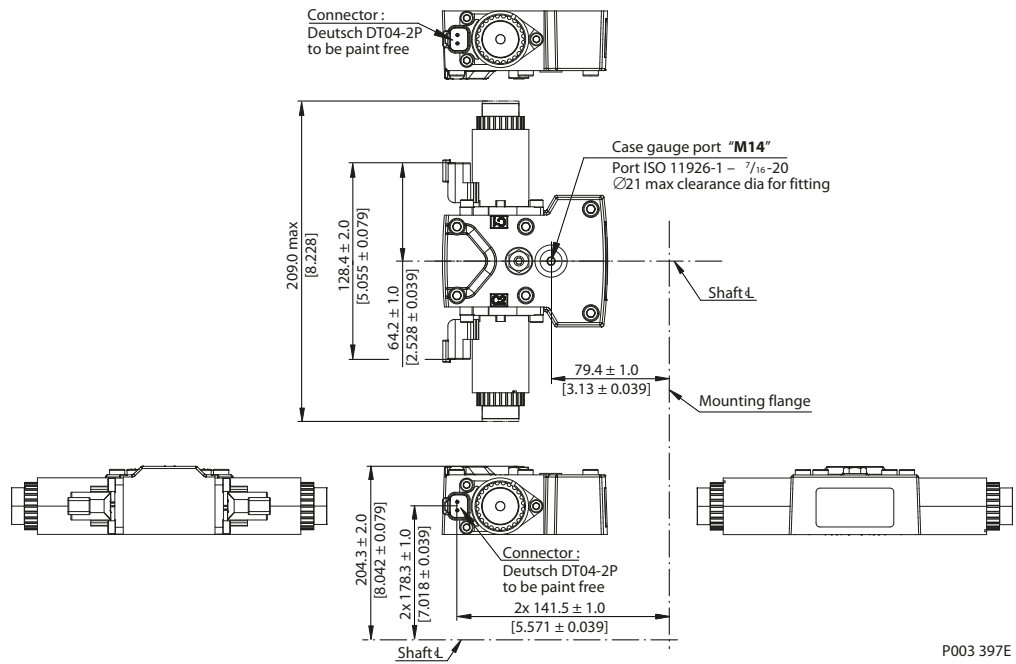

Please contact Danfoss representative for specific installation drawings.

## Controls

### Automotive Control (AC) Dimensions

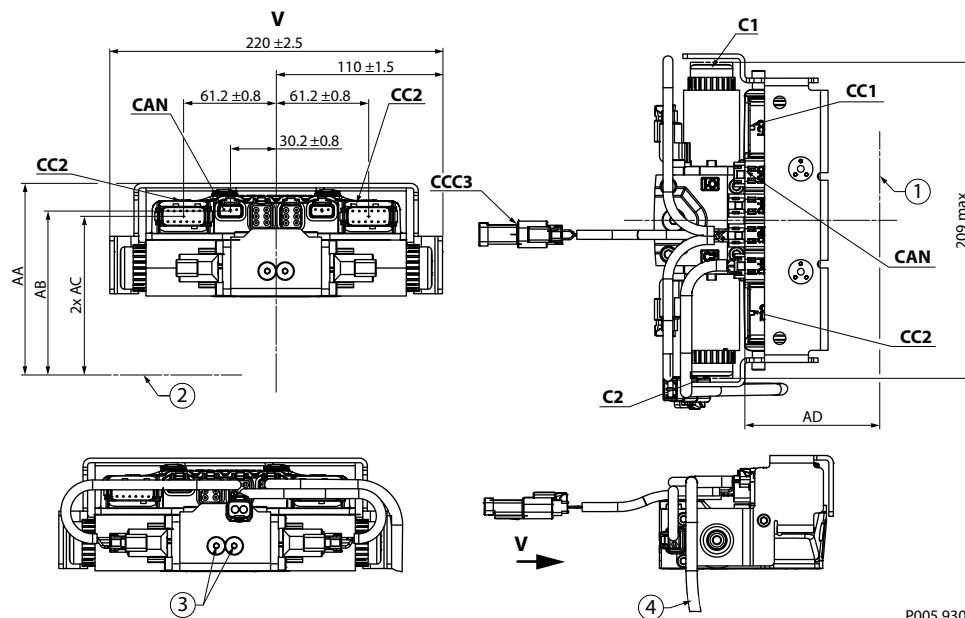

P005 930

1. Mounting flange
2. Shaft
3. Plug removing can cause contamination issues
4. PPU wire harness is factory installed to speed sensor

#### Dimensions, (mm)

Callout	Value
AA	208.9 ±2.5
AB	190.5 ±1.2
AC	2x 187.1 ±1.2
AD	89.2 ±0.8

#### Connectors description

Port	Description
C1 C2	Control MOR; Depressing the plunger mechanically moves the control spool. Actuation allows full stroke pump response as per coil and rotation dependent control logic.
CC1	Control connector Deutsch DTM04-12P -A; Paint free
CC2	Control connector Deutsch DTM04-12P -B; Paint free
CCC3	Control connector Deutsch DT06-2S; Paint free; For using connector the plug may be removed.
CAN	Control connector Deutsch DTM04-3P; Paint free; For using connector the plug may be removed.

Please contact Danfoss representative for specific installation drawings.

**Controls**

**Forward-Neutral-Reverse (FNR) with manual override, options A9 (12 V) / B1 (24 V)**

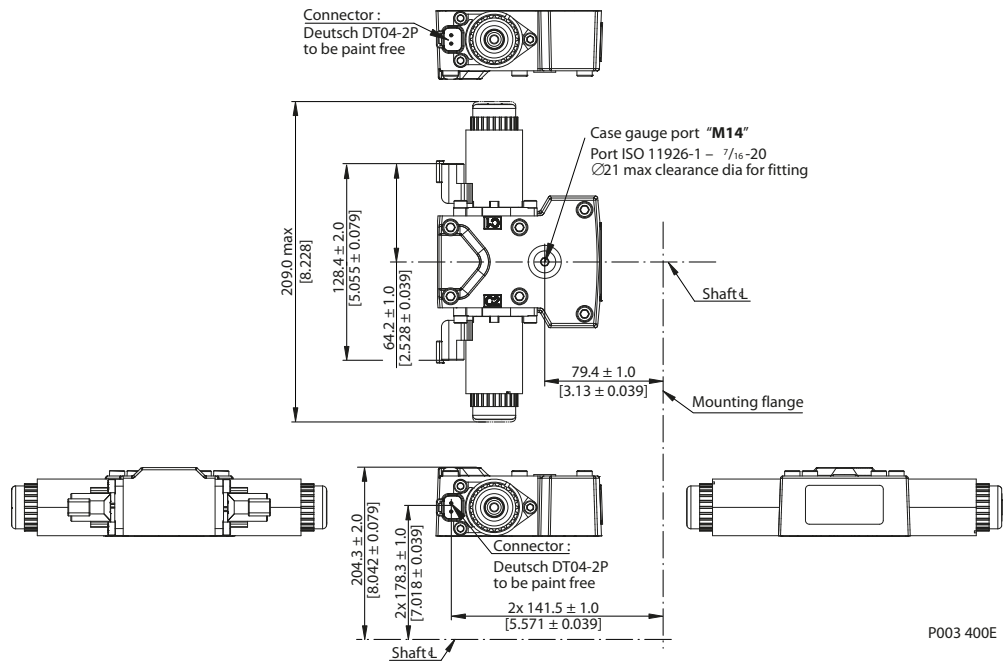

Please contact Danfoss representative for specific installation drawings.

**Filtration**

**H1P 115/130 suction filtration, option L**

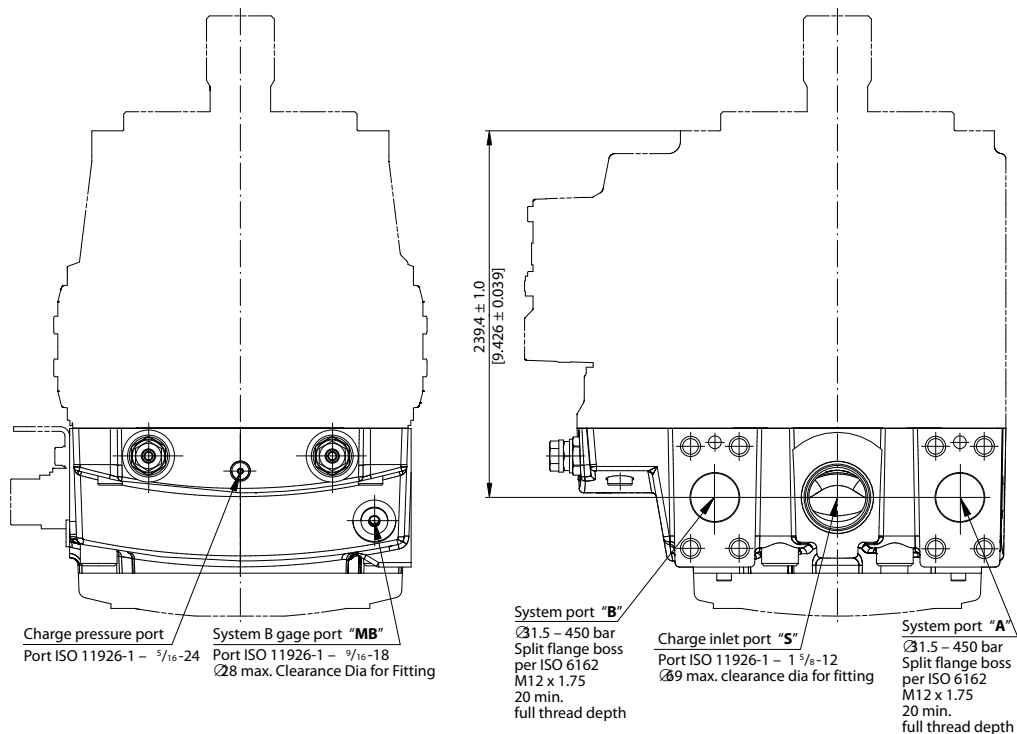

P003 403E

Please contact Danfoss representative for specific installation drawings.

**Filtration**

**H1P 115/130 filtration, option M**

*Integral full flow charge pressure filtration with filter bypass sensor, option M*

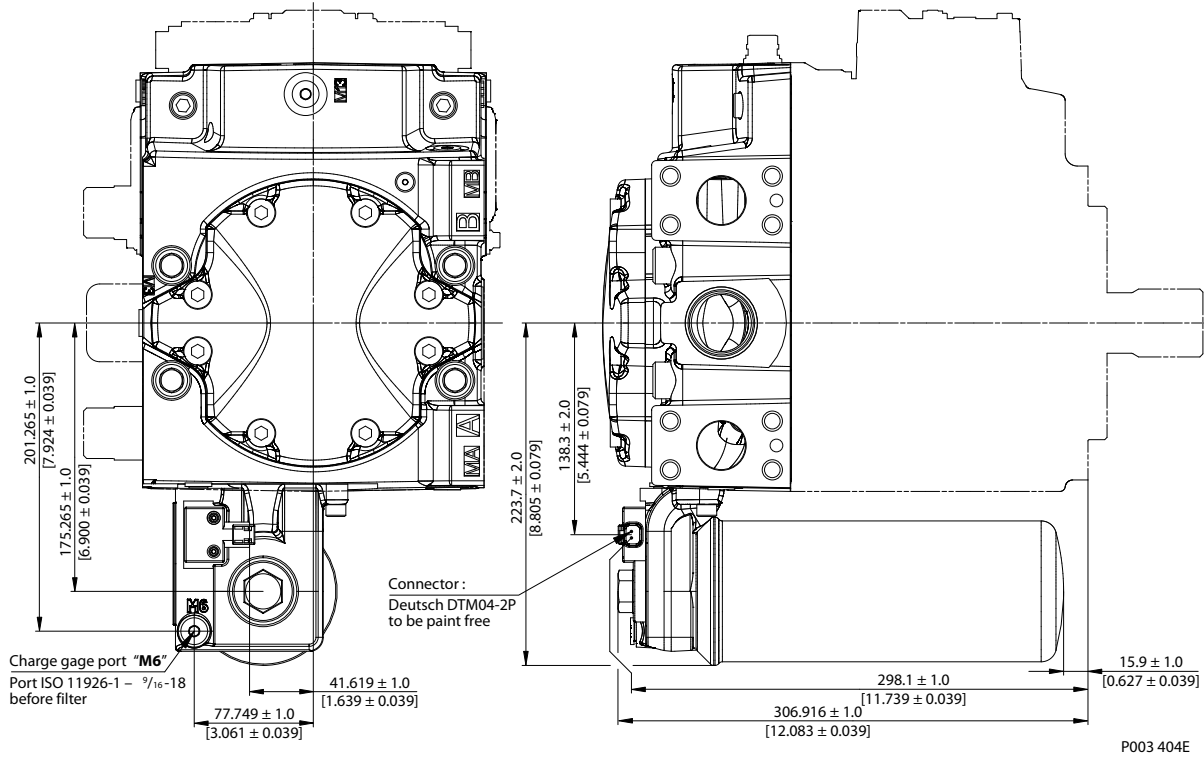

Please contact Danfoss representative for specific installation drawings.



**Products we offer:**

- Bent Axis Motors
- Closed Circuit Axial Piston Pumps and Motors
- Displays
- Electrohydraulic Power Steering
- Electrohydraulics
- Hydraulic Power Steering
- Integrated Systems
- Joysticks and Control Handles
- Microcontrollers and Software
- Open Circuit Axial Piston Pumps
- Orbital Motors
- PLUS+1® GUIDE
- Proportional Valves
- Sensors
- Steering
- Transit Mixer Drives

**Danfoss Power Solutions** is a global manufacturer and supplier of high-quality hydraulic and electronic components. We specialize in providing state-of-the-art technology and solutions that excel in the harsh operating conditions of the mobile off-highway market. Building on our extensive applications expertise, we work closely with our customers to ensure exceptional performance for a broad range of off-highway vehicles.

We help OEMs around the world speed up system development, reduce costs and bring vehicles to market faster.

Danfoss – Your Strongest Partner in Mobile Hydraulics.

**Go to [www.powersolutions.danfoss.com](http://www.powersolutions.danfoss.com) for further product information.**

Wherever off-highway vehicles are at work, so is Danfoss. We offer expert worldwide support for our customers, ensuring the best possible solutions for outstanding performance. And with an extensive network of Global Service Partners, we also provide comprehensive global service for all of our components.

Please contact the Danfoss Power Solution representative nearest you.

**Comatrol**

[www.comatrol.com](http://www.comatrol.com)

**Turolla**

[www.turollaocg.com](http://www.turollaocg.com)

**Hydro-Gear**

[www.hydro-gear.com](http://www.hydro-gear.com)

**Daikin-Sauer-Danfoss**

[www.daikin-sauer-danfoss.com](http://www.daikin-sauer-danfoss.com)

Local address:

**Danfoss  
Power Solutions (US) Company**  
2800 East 13th Street  
Ames, IA 50010, USA  
Phone: +1 515 239 6000

**Danfoss  
Power Solutions GmbH & Co. OHG**  
Krokamp 35  
D-24539 Neumünster, Germany  
Phone: +49 4321 871 0

**Danfoss  
Power Solutions ApS**  
Nordborgvej 81  
DK-6430 Nordborg, Denmark  
Phone: +45 7488 2222

**Danfoss  
Power Solutions Trading  
(Shanghai) Co., Ltd.**  
Building #22, No. 1000 Jin Hai Rd  
Jin Qiao, Pudong New District  
Shanghai, China 201206  
Phone: +86 21 3418 5200

Danfoss can accept no responsibility for possible errors in catalogues, brochures and other printed material. Danfoss reserves the right to alter its products without notice. This also applies to products already on order provided that such alterations can be made without changes being necessary in specifications already agreed. All trademarks in this material are property of the respective companies. Danfoss and the Danfoss logotype are trademarks of Danfoss A/S. All rights reserved.